



Bricsys®

Bricsys 24/7 (old UI)





Contents

1.	Getting Started	6
1.1	Working with documents	6
1.1.1	Structure app	6
1.1.2	Upload	6
1.1.3	Online viewer	7
1.1.4	Columns	7
1.1.5	Thumbnails	8
1.1.6	Document details	8
1.1.7	Action menu	10
1.1.8	Transfer tool	11
1.2	Document Viewer	12
1.2.1	Overview	12
1.2.2	Annotations	13
1.3	Communication	15
1.3.1	Types of communication	15
1.3.2	Notifications	15
1.3.3	Notes	15
1.3.4	Annotations	16
1.3.5	Messages	17
1.3.6	Recipients	17
1.3.7	Communication preferences	18
1.4	Tasks	19
1.4.1	Dashboard	19
1.4.2	My Tasks	19
1.4.3	Completed tasks	21
1.4.4	Document details	21
1.4.5	Communication preferences	21
1.5	Profile Settings	22
1.5.1	1. Edit personal details	23
1.5.2	2. Choose your interface language.	23
1.5.3	3. Send me a daily overview	23
1.5.4	4. Send me a daily task overview	23
1.5.5	5. Stop task notifications	23
1.5.6	6. Add revision to document name on download	23
1.5.7	7. Change your password	23
1.5.8	8. Folder subscription overview	24
1.5.9	9. Access tokens	24
1.5.10	10. Merge your account	24
1.5.11	11. Connection info	24
1.6	Layout and functionalities	24
1.6.1	1. Project Bar	24
1.6.2	2. App Bar	25
1.6.3	3. App Menu	26
1.6.4	4. App Content	27
1.6.5	5. Actions	27
1.6.6	Views	28
2.	Applications	30
2.1	Documents	30
2.1.1	Structure app	30



Contents

2.1.2	Document status	30
2.1.3	Document inspector	30
2.1.4	Column selector	31
2.1.5	Download	31
2.1.6	Edit	32
2.1.7	Copy	33
2.1.8	Move	33
2.1.9	Add to binder	33
2.1.10	Print to PDF	33
2.1.11	Delete	34
2.1.12	Attach document	34
2.1.13	Public share	35
2.1.14	QR Code	35
2.1.15	Folder notification	35
2.1.16	Document Details	35
2.2	Binders	39
2.2.1	Overview	39
2.2.2	Different ways to use a binder:	39
2.3	Dashboard	40
2.3.1	Project details	40
2.3.2	Recent documents	40
2.3.3	Upcoming events	40
2.3.4	Recent messages	41
2.3.5	Tasks	41
2.3.6	Activity-stream	41
2.4	Project Structure	41
2.4.1	Document & Binder folders	41
2.4.2	Project tree	41
2.4.3	Folder types	41
2.4.4	Project info	42
2.5	Address book App	43
2.5.1	Address book views	43
2.5.2	Actions	43
2.6	Calendar	45
2.6.1	Add event	45
2.7	Reports	46
2.7.1	Tasks	47
2.8	Messages	47
2.8.1	New message	48
2.9	Forum	50
2.10	Links	51
2.11	Workflows	52
2.11.1	What is a workflow	52
2.11.2	Obsolete workflows	52
2.11.3	Create workflow	52
2.12	Forms	52
2.12.1	Metadata	53
2.12.2	Attachment	54
2.12.3	Database	55



Contents

2.12.4	Form viewer	56
2.13	BIM Model Manager	57
2.13.1	Centralize, store and manage your BIM	57
2.13.2	Upload from BricsCAD with Full XREF management	57
2.13.3	3D Viewer: View and explore your BIM	58
2.13.4	IFC	59
2.14	Relations	59
2.14.1	Add relation	59
2.14.2	Access	61
2.15	Transfer Tool	61
2.15.1	Download and upload multiple documents	62
2.15.2	Upload folder or a complete folder structure to Bricsys 24/7	62
2.15.3	Download folders from Bricsys 24/7 to your device	62
2.15.4	Open a document	62
2.15.5	Synchronization	63
2.15.6	Downloads	64
3.	Managing Projects	65
3.1	Setting up a project	65
3.1.1	Add project	65
3.1.2	Administration app	66
3.1.3	Settings	66
3.1.4	Structure	66
3.1.5	Folder Access	68
3.1.6	Users	69
3.2	Setting up workflows	70
3.2.1	Add workflow folder	70
3.2.2	Add workflow	71
3.2.3	Creating a new workflow	71
3.2.4	Releasing a workflow	75
3.2.5	Attach workflow	76
3.2.6	Reassign task	76
3.2.7	Cancel / delete workflow	76
3.2.8	Delete user	77
3.3	Setting up metadata	78
3.3.1	Form folder	78
3.3.2	Create form	78
3.3.3	Form access	80
3.3.4	Attach form	81
3.3.5	Reservations	81
3.3.6	Advanced search	82
3.3.7	Filter	83
4.	Administration	84
4.1	Overview	84
4.2	Settings	84
4.2.1	Basic project information	85
4.2.2	Document settings	85
4.2.3	Time and date setting	87
4.2.4	Administrator settings	87
4.2.5	Recycle bin settings	88



Contents

4.3	Structure	88
4.3.1	Project tree	88
4.3.2	Structure inspector	89
4.3.3	Add Folder	89
4.3.4	Folder subscription overview	91
4.3.5	Add workflow	91
4.3.6	Add form	92
4.4	Users	93
4.4.1	Add user	94
4.4.2	Send account information	94
4.5	Roles	94
4.5.1	Role inspector	94
4.5.2	Add role	94
4.6	Folder Access	95
4.6.1	Folder access inspector	96
4.6.2	Access types	96
4.6.3	Selection bar	96
4.6.4	Toggle access	96
4.6.5	Create Snapshot	97
4.6.6	Revert Snapshot	97
4.7	Admin Access	97
4.7.1	Access	97
4.8	Table Administration	98
4.8.1	Table list	98
4.8.2	Data access	98
4.8.3	What does access on the data mean?	99
4.8.4	Data Access example	99
4.8.5	Download list	100
4.8.6	Upload CSV	100
4.9	Audit Report	101
4.9.1	Selection bar	101
4.9.2	Results	101
4.9.3	Search in action	102
4.10	Recycle bin	102
4.10.1	Empty Bin	102
4.10.2	Restore	103
4.10.3	Delete	103
5.	FAQ	104
5.1	I don't find the guest role anymore. How can I share information with guest users?	104
5.2	Is it possible to delete an annotation, a notification or a note ?	104
5.3	Problems logging in using the new Secure Login page	105
5.3.1	Why is there a new login system?	105
5.3.2	What's changing?	107
5.4	I don't see all applications in the app bar	107
5.4.1	Folder type	107
5.4.2	Access	107
5.5	I can't send notifications about a document	107
5.6	I don't see a specific user when sending a notification	107



Contents

5.7	I want to stop receiving task notifications in my email_____	108
5.8	How do I reassign a workflow task to another user_____	108
5.8.1	Workflow coordinator_____	108
5.8.2	Project administrator_____	110
5.8.3	Requirements_____	110
5.9	Why is the workflow task assigned to another user_____	110
5.9.1	Access rights_____	110
5.9.2	Reassign actor_____	110
5.10	How do I delete a workflow_____	111
5.10.1	Delete access_____	111
5.10.2	Workflow in use or not_____	111



1. Getting Started

1.1 Working with documents

1.1.1 Structure app

The structure app is the only app that gives you access to document and binder folders. Binder folders contain a collection of items.

Document folders are shown with a gray icon, if the folder has documents it will be dark gray and if it's empty it will be shown with a light gray color.

Let's open a document folder.

1.1.2 Upload

Click on the upload button in the action menu to upload a new document. The dialog will ask you to select one or multiple documents you wish to upload. You can drag and drop the documents directly from your local machine to the upload dialog or manually select them.

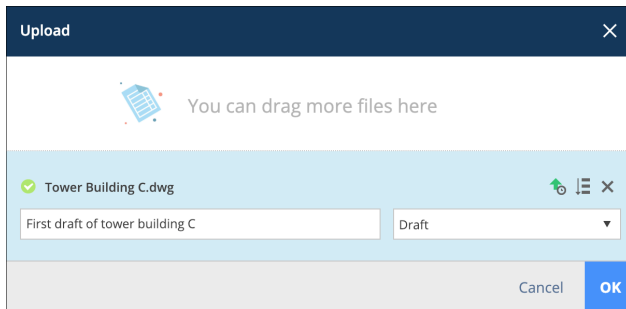

Once the documents have been added, the dialog will show the upload progress with a blue progress bar and ask for an optional description and a document status. In case you see more fields popping up it means the administrator has set up metadata for this folder.

Metadata is a great way to add more detailed information to a document in order to easily search, filter and group documents.

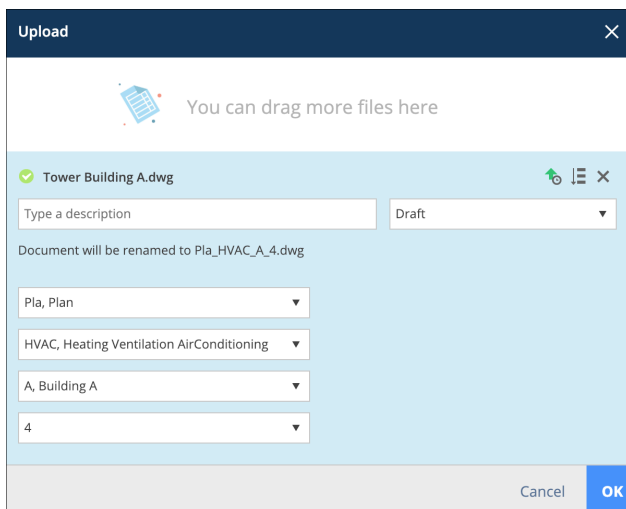



If you want to add the same values for all the documents, simply click the “apply to underlying documents” icon to set the values.

Hit the upload button to add your documents to the folder.

If you need to upload a huge set of documents at once, you can use our transfer tool.

1.1.3 Online viewer

Once a document is uploaded and our online viewer supports the document format, Bricsys 24/7 will undertake multiple actions to make the document viewable online.

1.1.4 Columns

Document Inspector

The top right of the table contains the document inspector column. It gives you a quick overview of some of the details of a document.

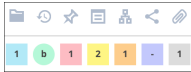

	Is the document added to a binder
	How many revisions were made
	How many annotations were added
	How many notes were added
	How many workflows were attached
	How many times has this document been shared
	How many other documents are linked to this document

If you hover over the fields in the document inspector, more information will appear. If you click this information, you will jump immediately to the linked information.

Note: Sometimes there is a colored line underneath the number of workflows:

- green means that the workflow is finished
- red means that there is a task assigned to you
- no line means that the workflow is busy but you are not assigned to a task

Column selector

If you want to hide columns or show extra metadata columns in case the folder has metadata, you can click the “...” icon on the top right and click the columns you want to show or hide.

1.1.5 Thumbnails

On the top right you can switch to thumbnail view, this gives you a visual overview of the documents in the folder.

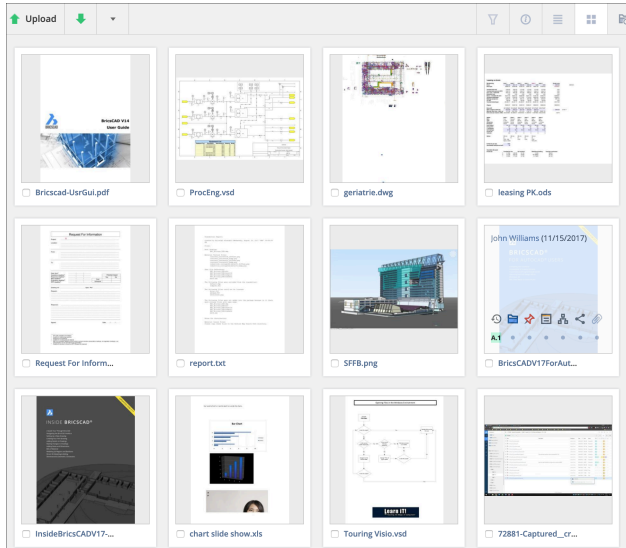

1.1.6 Document details

By clicking on the document name you open the document details dialog. This dialog contains all the information of a document.

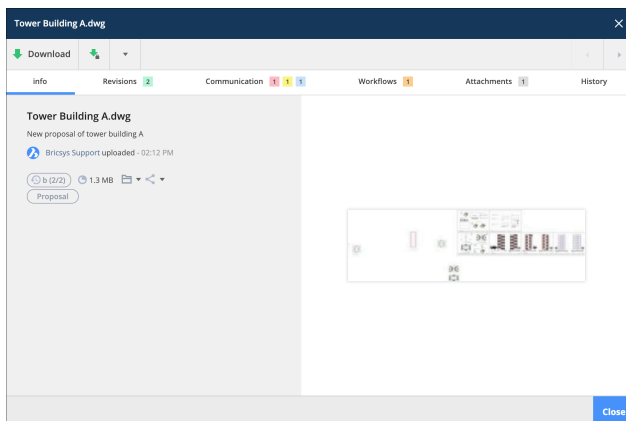

The tabs on top of the dialog group the information by category.

Info

Contains the same information as the columns in the document app as well as the locations where the document is displayed: folder and binders and if the document has been shared publicly.

Click on the preview on the right to view the document in our online viewer.



Revisions

The process from draft to delivered document is saved by revisions. Each revision has a status and description to indicate its process.

This section contains all the revisions a document has. There is no limit on the number of revisions. The administrator decides how revisions are displayed:

- 0,1,2,3,4...
- 1,2,3,4,5...
- a,b,c,d,e...
- A,B,C,D,E...
- -a,b,c,d...
- -A,B,C,D...

Revisions can have a major and minor version. This is decided by the administrator of the project. This way a revision could be "A.1" instead of just "1".

Click on a revision to view the details of the revision on the right.

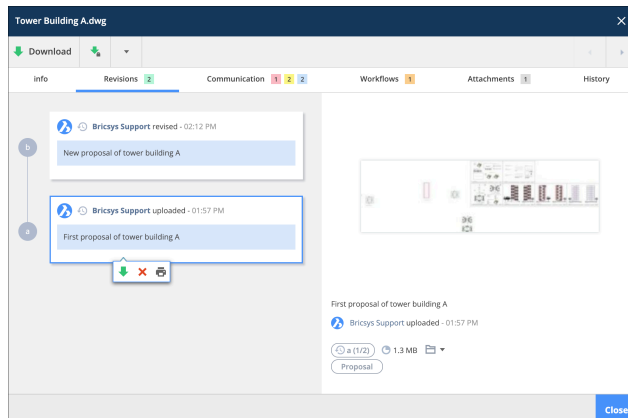

Hover over a revision to

- Download
- Print to PDF
- Delete (only if you have delete access on the document and the project administrator allowed the deletion of revisions)

Clicking on a specific revision will filter the communication and attachments in the corresponding tabs to the selected revision.

Communication

View all the communication concerning this document, easily filter on the type of communication and revision.

Workflows

View the workflows that are active, finished or canceled. If a workflow has active tasks and you are assigned to a task, you can respond to the task from here.

Attachments

View all the items that are linked to this document and the items the document is part of.

History

Take a look at the history of this document.

1.1.7 Action menu

The menu on the top will show you which actions you can perform in this document folder. This is set by the administrator of the project.

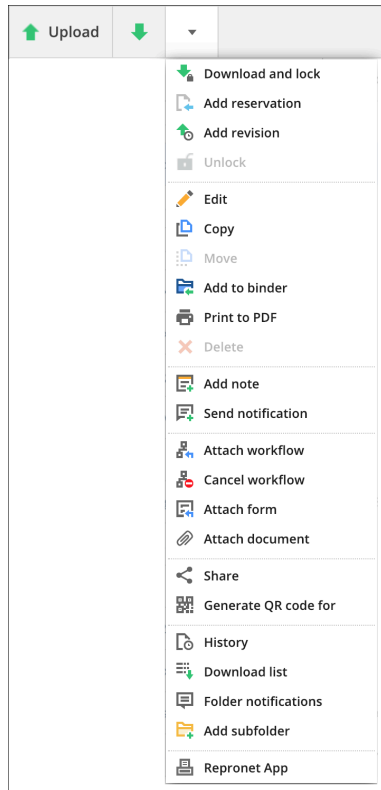

Some actions are based on selections only. If the folder has documents you can hover over a document and see the actions available on that document.

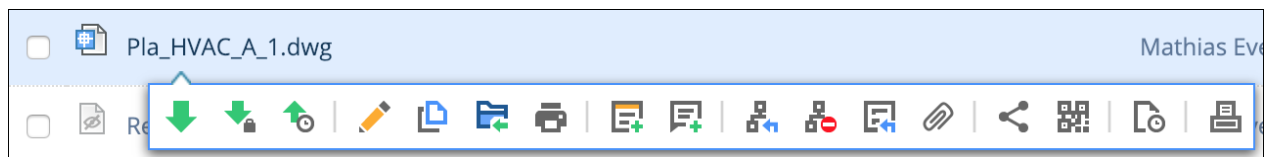

Delete

When you delete a document it will be stored in the recycle bin. Only the administrator can access the recycle bin and delete it definitively or restore it to the original document folder.

You can't delete a document and upload a document with the same name because the deleted document is stored in the recycle bin.

Attach document

Gives you the opportunity to manually upload a new document from you local machine and attach it to the document directly or link the document to another document in your project.

When linking to another document on the project the advanced options let you choose whether you want to link a specific revision to a specific revision. By default the documents are always linked to the last version of each document.

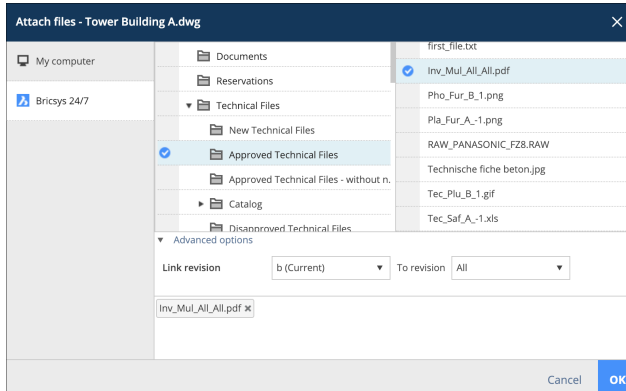

Once the document is linked you can see it in the [document inspector](#) and in the details of the document. If it is linked to another document, you will see the link in the other document as well.

When uploading dwg files from within BricsCAD or AutoCAD with our [Bricsys 24/7 connect plugin](#), xrefs will be linked automatically for you.

Public share

Share documents with people who aren't part of the project by creating a unique URL and send it to them. Everyone with this link can open the document in the viewer without them having to log in on the project.

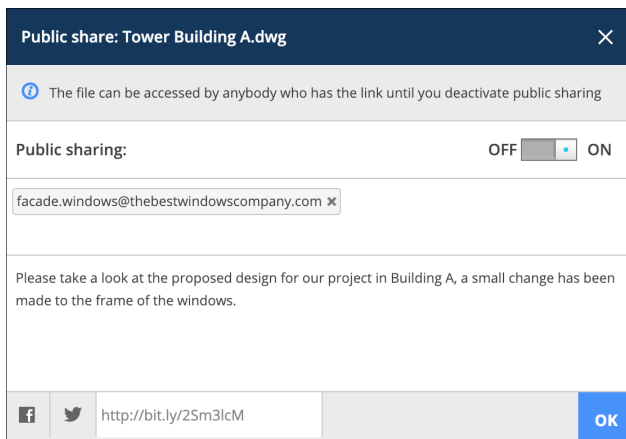

Note: You can always turn off the share by toggling the public share slider on the top right. After you turned off the sharing, the URL link will no longer work.

Watch out: If you re-share by doing the same action, another URL will be generated, different from the old UR you generated the first time.

1.1.8 Transfer tool

With the transfer tool, available for Windows and Mac, you can easily upload hundreds of documents and folders to Bricsys 24/7.

As an admin, it's also a great tool to set up a project structure in a couple of clicks.



1.2 Document Viewer

1.2.1 Overview

The Bricsys 24/7 viewer gives you the opportunity to view more than 70+ file formats* online without the need to install any software or buy extra licenses.

Click on the document icon or on the preview picture to open the viewer.

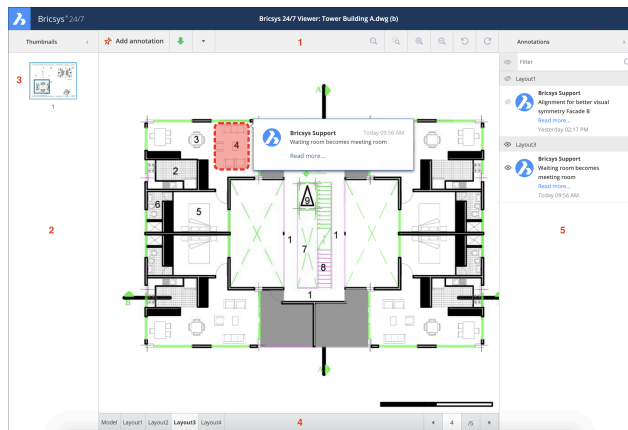

* 70+ Documents:

- **Text formats:** asm, bat, c, css, cpp, cxx, gene, h, hxx, idh, idl, inl, java, log, lsp, rss, sql, tpl, text, txt, xml.
- **Image formats:** bmp, gif, jpg, jpeg, pcx, pgm, pict, png, ppm, tga, tif, tiff, xbm, xpm, xwd, ai, psd.
- **Office formats:** doc, docx, dot, dotx, mpp, odf, odg, odp, ods, odt, potx, pps, ppsx, ppt, pptx, rtf, xls, xlsx, xlsx, xlt, xltx, vsd.
- **CAD formats:** dwg, dxf, dwfx, dxf, dgn, plt, hp, hpg, hpg.
- **Other:** htm, html, pdf, ps, zip.

The viewer contains:

1 Title bar



- Thumbnail pages overview
- Action menu
- View, zoom and rotation options
- Annotations

2 Pages overview

On the left, all the available pages are shown with a thumbnail for each page. You can easily scroll through the pages and clicking on a page will open that page in the viewer.

3 Current view of the document



The selected page is highlighted and the area that is viewed marked on the preview.

4 Tabs of the document (DWG, Excel...)



In case a document has multiple tabs (layouts or sheets), these will be shown on the bottom of the viewer.

5 Annotations

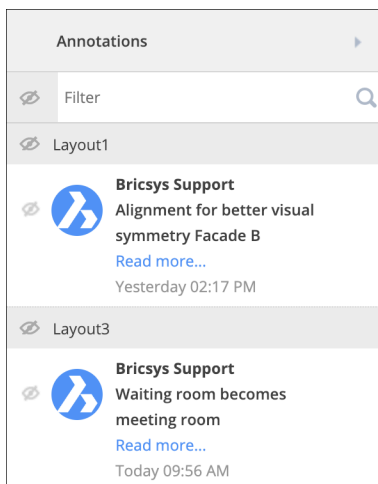

In case the documents has annotations a red counter will mark the amount of annotations the document has. You can open the annotations panel by clicking the annotations icon. Selecting an annotation will highlight the annotation on the correct page and tab.

1.2.2 Annotations

Annotations are a great tool to comment on a specific area of the document.

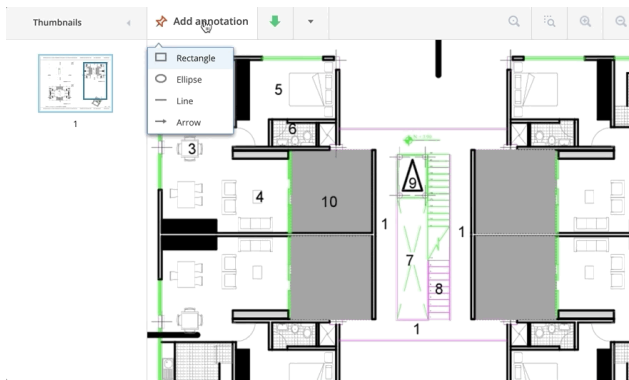

Add annotation

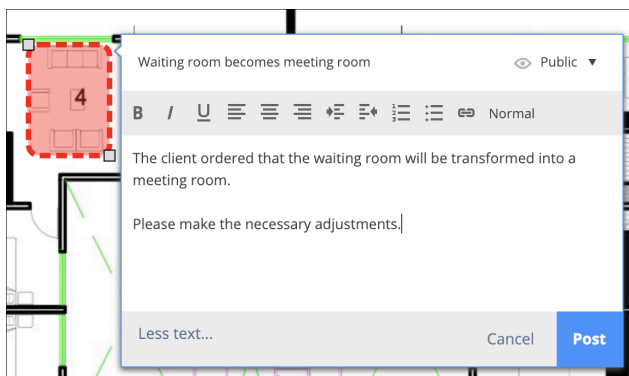

To create an annotation, you need to:

- 1 Select the type of annotation
- 2 Click on the area of the current view of the document
- 3 Drag the area you want the annotation to cover
- 4 Fill in a subject (title)
- 5 If necessary, click on the "More text" to fill in a more detailed description of your remark
- 6 Save

View annotation

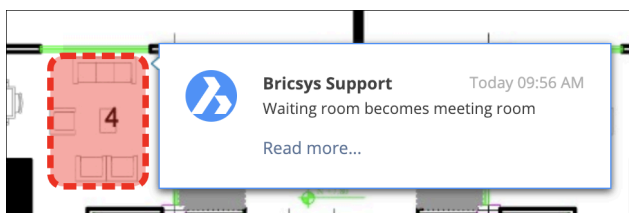

- 1 Open the annotations panel on the top right
- 2 Select an annotation



1.3 Communication

Communication is the beating heart of project collaboration in Bricsys 24/7. In your profile you can review your Communication preferences.

1.3.1 Types of communication

In Bricsys 24/7 we have four types of communication

- Notifications
- Notes
- Annotations
- Messages

1.3.2 Notifications

Easily inform other project members that can view the item about it. Typical examples are sending a notification about a newly uploaded document, a selection of documents etc.

Add the recipients, just like you would do for an email, write a subject and a message. The recipients will receive an email with your message and the items you are referring to.

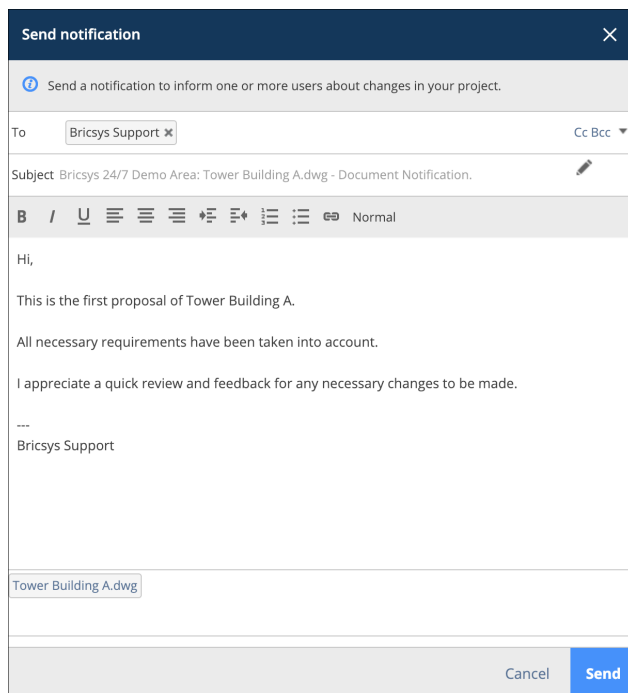

1.3.3 Notes

Just like sticky notes, a note is visible over all the revisions of a document. You can use private notes or public notes.

Private note

When you select members of the project in the note, the note becomes private and only those who are a recipient of a note can view the note.

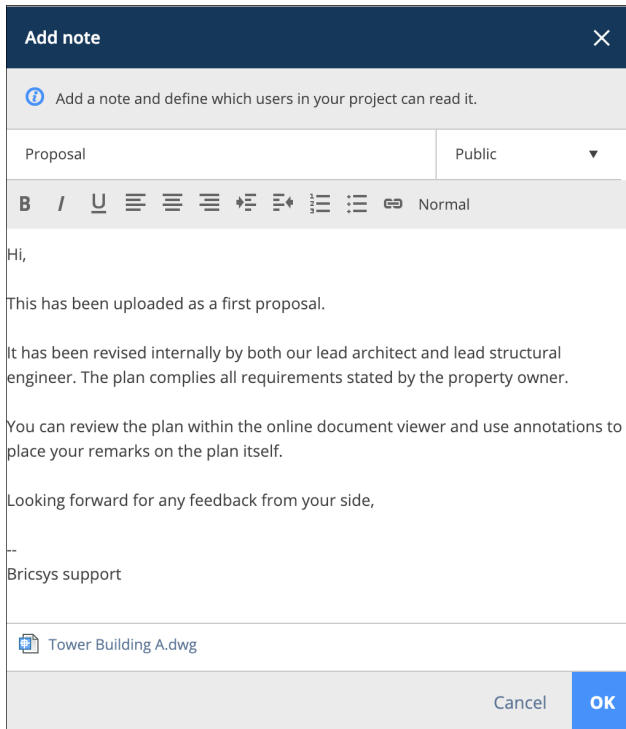

Note that administrators can enable a feature allowing them to view all communications, including private communication.

1.3.4 Annotations

A great way to mark an area of a document and comment about it. Annotations can only be created in our online viewer. Simply choose the type of annotation you want to add, select the area and add your message.

By default only a subject is shown, click on the **more** link to add a description to your comment.

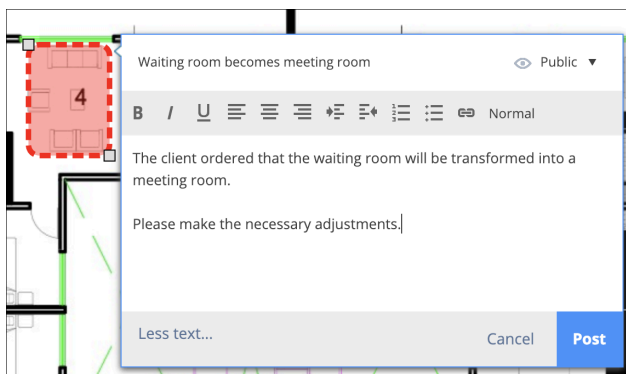

You can send private annotations that are visible only for selected users, or public annotations that can be seen by all users who have access to the document.

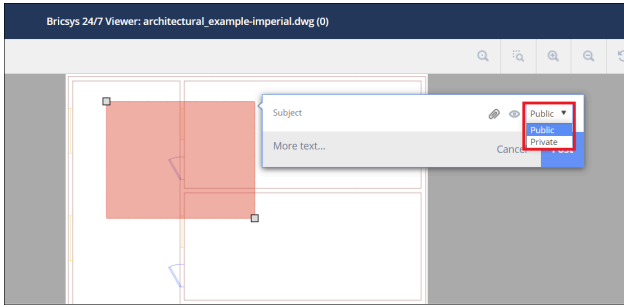

Annotations are revision based, this means you cannot see the annotation of previous revisions when viewing the latest version of the document.

1.3.5 Messages

Messages works just like your email does but it doesn't get lost, keep track of your emails. It's a great way to communicate effectively with other project members and not lose the information.

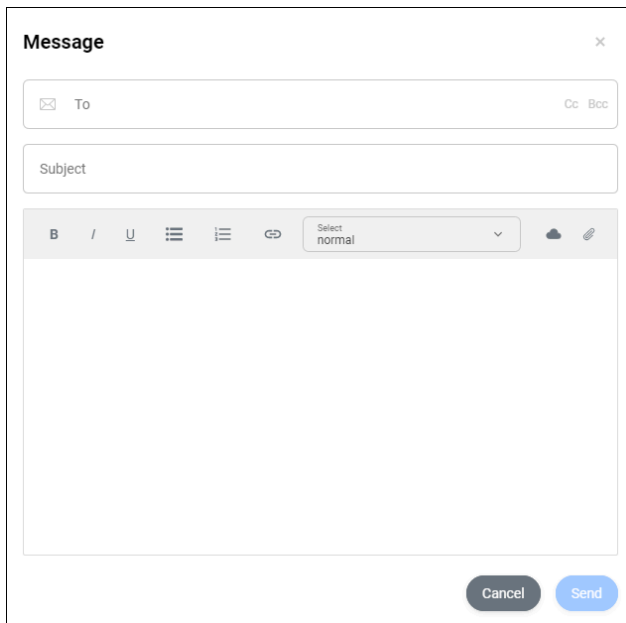

The administrator of the project can also enable email forwarding for a specific email address. This makes it possible to send an email to the specific email address and have the email appear in Bricsys 24/7.

1.3.6 Recipients

Keep in mind that only project members who can view the item will be selectable. Simply type the name of a project member or select one of the mail lists setup by the project administrator.

After selecting a mail list, you can click on the list to deselect certain members.

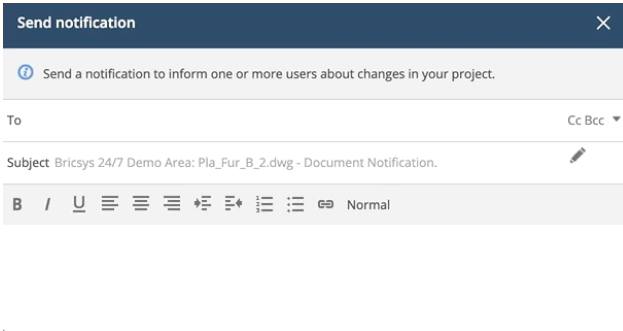

If you cannot send a notification or assign members in a note or mail message, this means that the administrator of the project did not give you access to communicate with other members of the project.

1.3.7 Communication preferences

Easily let Bricsys 24/7 know which communication you wish to receive in your inbox and when.

Open the profile dialog by clicking on the picture on the right top corner of Bricsys 24/7.

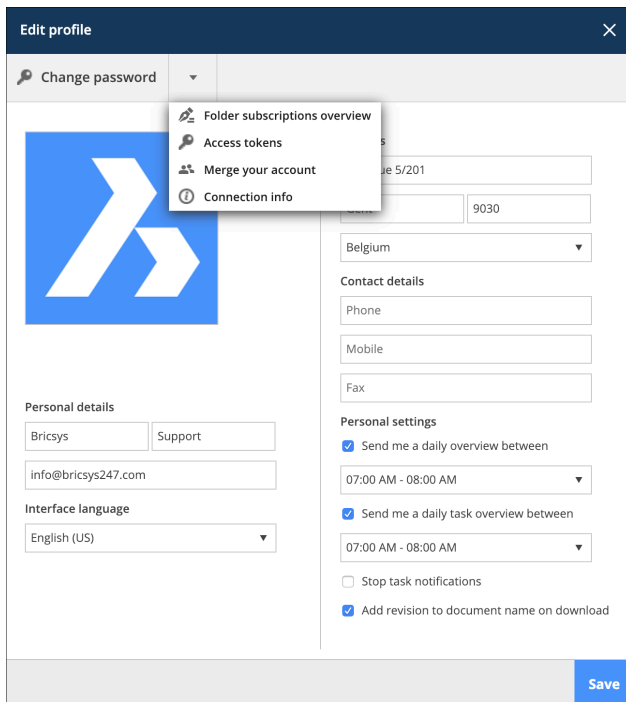

Daily overview

The daily overview email informs you of all the newly added documents you can view in Bricsys 24/7.

Daily task overview

Receive an overview of all your open tasks in Bricsys 24/7.

Stop task notifications

By checking this option you will not receive an immediate email with the task that is assigned to you.

Subscriptions

In the action menu of your profile settings you can view and edit your subscriptions. You need to be logged into a project to view the subscriptions action.

The subscriptions are folder based per project, you can add or remove folders and indicate when you wish to receive an email.

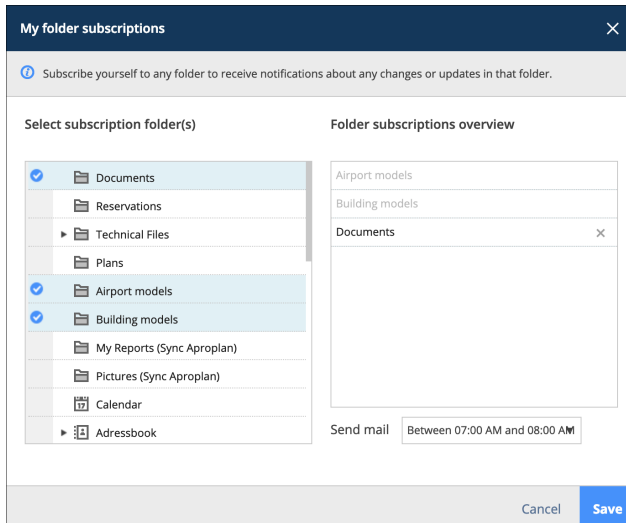

Administrator subscriptions

Some subscriptions cannot be removed because they are enforced by the administrator of the project. In the example above, both "Airport models" and "Building models" cannot be unsubscribed by the user since the administrator has set the subscription.

1.4 Tasks

Tasks are part of a process that was set up by an administrator of the project using workflows. A task is an activity assigned to a project member.

You can find your tasks in

- Dashboard
- My Tasks
- Document details

and change your task Communication preferences in the profile dialog.

1.4.1 Dashboard

The dashboard app shows you the open and overdue tasks you are assigned to. Click on the task to open the details for the task.

Tasks		
Overdue		Overdue since
 Ask to CEO	 Pla_Fur_B_2.dwg	11/19/2018 07:12 PM
 Ask to CEO	 Pla_Fur_B_0.xlsx	11/28/2018 05:12 PM

1.4.2 My Tasks

In the My Tasks app on your left you can easily view all the open tasks that are assigned to you.

Each task shows the question that is asked and a selection of predefined answers you can choose from.

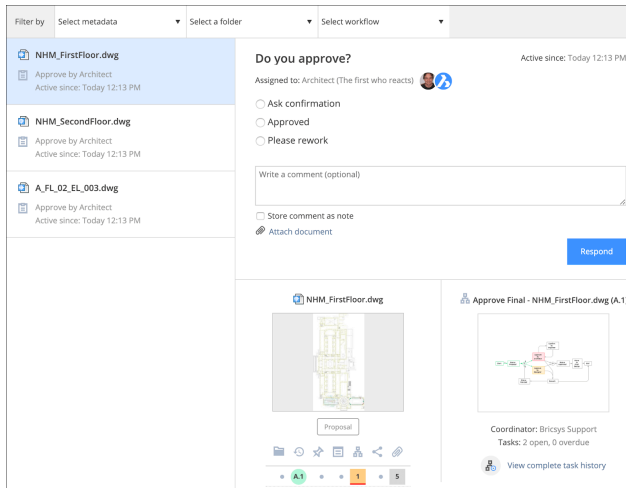

Comments

For each task, you can add a comment in case you wish to clarify your answer.

Attachments

You can add documents from your local machine or from Bricsys 24/7 related to the answer to your task. On the bottom of the task, you find the document the task is attached to and the workflow the task is part of.

Document

Click on the document preview to open the document in our online viewer or the document name to open the document details.

Workflow

For those interested, you can also view the workflow of which this task is part of and see the history of all the tasks executed before you.

Filter

Do you have too many open tasks and need to focus on a specific set of documents first? It's possible to filter your tasks by metadata, folder, and even workflow. On the top panel of the app, you'll find the filter options.

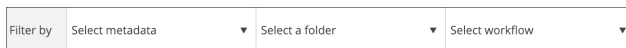



Do you approve this Technical File? Active since: 02/19/2019 11:06 AM
Due: 03/05 Tuesday 11:06 AM

Assigned to: WF_Architects (The first who reacts)

Not sure, Ask it to CEO
 Approve
 Disapprove please
 Rework please

Write a comment (optional)

Store comment as note
 Attach document

Respond

Pla_Dec_C_All.dwg

Draft

Approval of Technical Files V5 - Pla_Dec_C_All.dwg

Coordinator: Bricsys Support
Tasks: 2 open, 0 overdue

View complete task history

1.4.3 Completed tasks

If you wish to view your finished tasks, simply click the "Completed tasks" section on the left of the My Tasks app.

1.4.4 Document details

When viewing the details of a document, navigate to the workflows tab to view active workflows and check if you are part of a task to be executed.

Click the Respond button to open the task and reply to the task assigned.

1.4.5 Communication preferences

In the profile dialog you can select to receive a daily task overview and not to receive task emails.

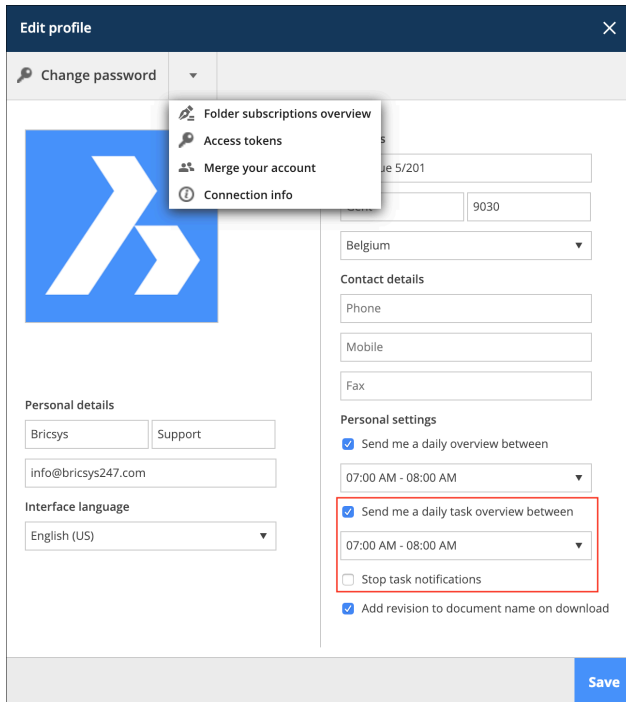

Daily task overview

Check this box and a time when you wish to receive a daily email in your inbox about all your open tasks over all the projects in Bricsys 24/7.

Stop task notifications

If you do not wish to receive task notifications.

1.5 Profile Settings

Click on the profile picture/avatar in the top-right corner of the Bricsys 24/7 screen. Here you can edit your profile settings.

Attention:

If you cannot edit this information, it means that the administrator did not give you the rights to edit your profile.

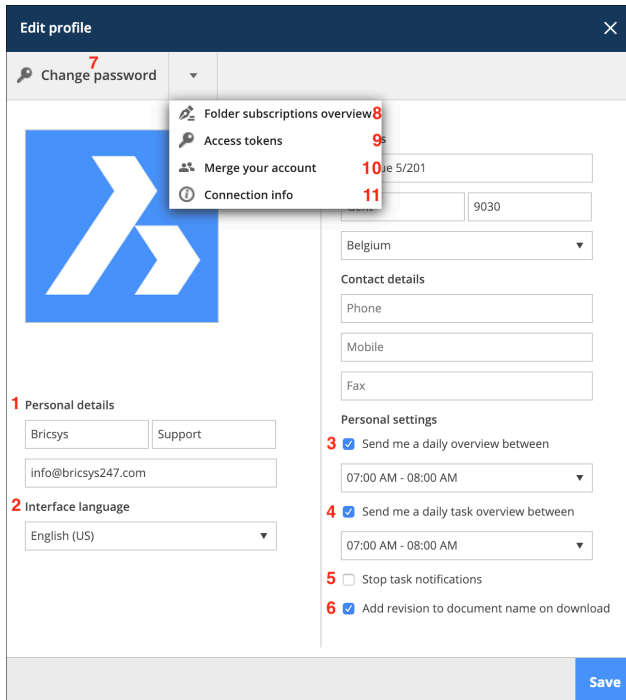

1.5.1 1. Edit personal details

Edit or fill in your personal details, avatar, address and/or contact details. If your email address has changed you can change it here to login with the new email address.

1.5.2 2. Choose your interface language.

Change the interface of Bricsys 24/7 to your preferred language.

1.5.3 3. Send me a daily overview

If you want a daily mail with all your notifications.

1.5.4 4. Send me a daily task overview

If you want a daily mail with all your open tasks.

1.5.5 5. Stop task notifications

If you do not want to get an e-mail notification when you are assigned to a new task.

1.5.6 6. Add revision to document name on download

If you want to add the revision to the document name when downloading. The revision will be added after the document name: document-**revision**.extension

Example: document named "PL_HVAC_001.dwg" with 3 revisions: A, B & C. When downloading the document it will be saved as "PL_HVAC_001-**C**.dwg"

1.5.7 7. Change your password

If you want to change your password.



1.5.8 8. Folder subscription overview

This option is only available once you log into a project.

When you subscribe to a folder, you will get a notification e-mail when something changes (upload, new revision, edit of a document...) in this folder.

The administrator of your project can also subscribe you to certain folders. These subscriptions cannot be undone, only the administrator has to right to update these.

1.5.9 9. Access tokens

For advanced users only. If you have a third party application that needs to connect to Bricsys 24/7 via our REST api, you can create a token here so you don't have to give your personal credentials (username and password) for the application to log in to Bricsys 24/7.

The application will have the same access using the token as yourself.

Once created you are also able to revoke the token, disabling the access for that application to Bricsys 24/7.

1.5.10 10. Merge your account

Merge the Bricsys 24/7 account you're logged in with, with another Bricsys 24/7 account by entering the username and the password of the other account.

1.5.11 11. Connection info

If you want to find basic information about your connection to Bricsys 24/7 you can use this action. Your download speed, browser, operating system will be shown here. Especially useful when you are submitting a new support request so our team has a better understanding of your local environment.

1.6 Layout and functionalities

In this part of the Bricsys 24/7 help you find the default layout and grouping of the functionalities on Bricsys 24/7. Bricsys 24/7 contains a Project Bar(1), an App Bar (2), an App Menu (3) and an App Content (4) with Actions (5) and Views (6).

1.6.1 1. Project Bar

On top of the Bricsys 24/7 screen sits the Project Bar with basic information and basic actions.

Watch or edit profile

See Profile Settings [on page 22](#).

Jump to the project list

Displays a list of all your projects. Click a project in the list to open the project. Only one project can be opened simultaneously.

▶ Current Location on the project

Search in the project

A quick and easy way to find what you're looking for. Simply type the first three letters of what you need and all results will popup under your search query.



Optional: Advanced search

The advanced search lets you specify specific criteria to narrow down search results.

- Search Documents
- Search Messages
- Search Meta data (See [Form App](#))

Select language

If you want Bricsys 24/7 to remember your default language (See Profile Settings [on page 22](#)).

Help page

Go directly to the help page.

Log out

Always log out when you don't need to work in Bricsys 24/7 anymore. If you don't logout yourself, the system will log you out after one hour of inactivity for security reasons.

1.6.2 2. App Bar

On the left side of the Bricsys 24/7 screen, there is a vertical bar: the App Bar. In the App Bar, you can jump directly to the functionality you need. There are 12 different Apps, but you only see the Apps according to your access rights.

The Dashboard App

This is your central hub that monitors all your project related activities. It is subdivided in multiple sections:

- 1 Project details
- 2 Upcoming events
- 3 Recent documents (last 7 days)
- 4 Recent messages (last 7 days)
- 5 Tasks
 - Overdue tasks
 - Active tasks
- 6 Activity
 - All the recent project activity

The Structure App

This is a powerful document management tool. Here you find a comprehensive overview with the statuses and details of all objects in the project. This App is the core of the project and displays all project folders you have access to in a tree structure.

The Address book App

Allows you to manage all your project contacts. Contacts can be grouped together in organizations.

The Calendar App

Allows you to manage, track and lock all events and meetings.



The Report App

Allows you to review workflows by filtering on timeframe, workflow, folders and assigned actors for the tasks.

The Task App

Allows you to find all your tasks and filter them on metadata, folder and workflow.

The Messages App

Allows you to focus on clean project communications. Here you can send messages (mail) to other people in the project.

The Forums App

This is the place to discuss various subjects with other project participants.

The Links App

Allows you to share and view URL-links to external web pages.

The Workflow App

Allows you to design and edit workflows using an intuitive drag and drop editor.

The Forms App

Allows you to build forms and store metadata using a simple drag and drop system.

Administration App

Allows you to manage the project (Only visible for Administrators)

1.6.3 3. App Menu

The App Menu shows the name of the App you selected (in the App Bar) and its related folders and options. Except for the dashboard App, all Apps have an App Menu. If you click on the arrow next to the App Name, a drop-down list with the App Menu actions will appear.

Some actions will be disabled if you have insufficient rights or if the actions are currently not possible for you.

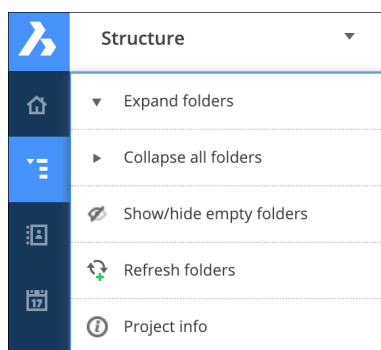

▼ **Expand folders**

Expands all folders in the App Menu.



► **Collapse folders**

Collapses all folders in the App Menu.

 **Show/hide empty folders**

 **Refresh folder**

 **View or extract Project info**

This opens a dialog with the folder structure with their content and size. The Download List option allows exporting this list to an Excel file.

1.6.4 4. App Content

The objects in the selected folder are displayed here. Because there are different Apps (See [App Bar](#)), the App Content will adapt according to the selected App.

On top of the App Content, you find Actions and a Views. Except for the Dashboard App all Apps will have an App Content with Actions and Views.

1.6.5 5. Actions

All the actions in the App Content are stored in two different bars. The actions in these menus adapt according to the App, access rights and/or the folders/objects you selected. You will only see the actions that are currently possible for you. According to the number of the selected objects, you can choose which bar you want to use.

If you do not see all the actions that are explained in the different Apps, it means you have insufficient rights for these actions (See [Introducing Bricsys 24/7](#)). To see which rights you have, see the folder information action in [Views](#).

- **Actions on a single object**

- **Actions on top of the App Content**

Click the checkbox of the object and select an action.

- **Hover Bar**

Hover over the object and select the action:

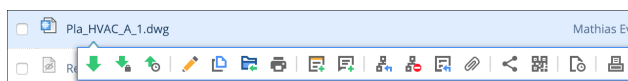

- **Actions on multiple objects**

- **Actions on top of the App Content**

Click the checkboxes of the objects and select an action.

For most Apps there is a main action, a secondary action and a drop-down list with additional actions.

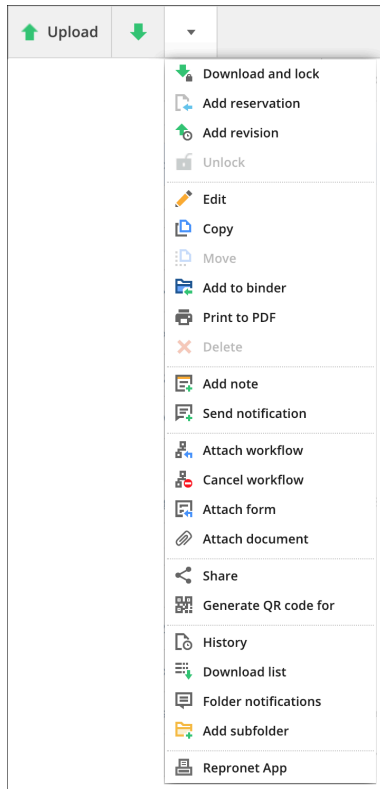

1.6.6 Views

In the top right corner of the App Content you can change the view of the App content. The Views adapt according to the App and folder you selected. Furthermore you can also filter or view information about your rights here.

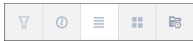

Depending on the application multiple views might be available. The image above displays the options for the documents folders:

Change view

Select the view of the App Content. List view or thumbnail view.

Filter

Filter the objects in the App Contents.

The filter Applies to the current folder only. This is different from the search function in the Title bar, where you can search the whole project.

Information

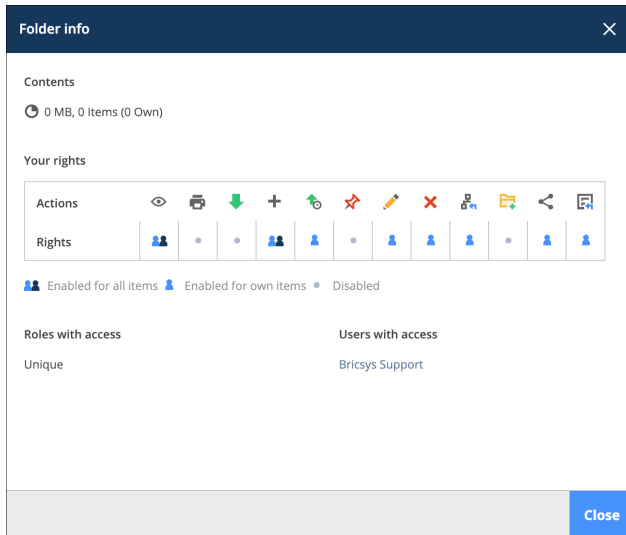

1. Actions

View rights	Print to pdf rights	Download rights	Add rights	Add revision rights	Add annotation rights	Edit rights	Delete rights

2. Access

No access	Access own Rights to objects that you created or uploaded in the folder	Access all Rights to all objects in the folder

3. Roles with access

If you have the rights to see them.

4. Users with access

Only if you have access to see other users you will see the users that have access to this folder.

5. Content of the folder

Displays the amount of items and items you own within the folder with its total size.



2. Applications

2.1 Documents

If you are new to documents we advise you to take a look at Working with documents [on page 6](#) first.

2.1.1 Structure app

Document folders can only be viewed from within the Structure app.

The app content of a document folder shows you the basic details of the documents.

<input type="checkbox"/> Name	Description	Uploaded by	Date	Size	Status								
<input type="checkbox"/> Tower Building A.dwg	New proposal of tower building A	Bricsys Support	02:12 PM	1.3 MB	Proposal								
<input type="checkbox"/> Tower Building B.dwg	Second proposal of tower Building B, reworked remarks	Bricsys Support	02:11 PM	1.3 MB	Proposal								

Sorting

Except for the items in the document inspector and the document icon, you can sort the documents by clicking on the header.

By default, the documents are sorted by the date they were added, the newest documents appear on top.

Checkbox

Click one or multiple checkboxes to select documents. Once checked, certain actions in the action menu may become available, depending on the access you have.

Document icon

Click the document icon to open the document in our online viewer. If you hover over the document icon, a preview of the document will be shown.

The document name

Click the document name to open the details of the document.

2.1.2 Document status

By default, Bricsys 24/7 provides multiple document statuses. The administrator of the project defines these statuses to project's standards.

Note that each revision has its own status.

2.1.3 Document inspector

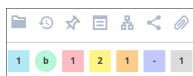

	Is the document added to a binder
	How many revisions were made
	How many annotations were added



	How many notes were added
	How many workflows were attached
	How many times has this document been shared
	How many other documents are linked to this document

If you hover over the fields in the document inspector, more information will appear. If you click on an entry, the information will open in a new dialog.

Sometimes there is a colored line underneath the number of workflows:

- green means that the workflow is finished
- red means that there is a task assigned to you
- no line means that the workflow is busy but you are not assigned to a task

2.1.4 Column selector

At the end of the table headers there's a "..." icon that you can use to show or hide certain columns. When working with metadata, the extra metadata columns are displayed here as well.

2.1.5 Download

There are two ways to download a document:

Download

Download the document to your local computer.

Download and lock

Download the document to your local computer and lock it to prevent it being edited and moved by other users.

Do not use this feature if you only want to download the document.

Upload

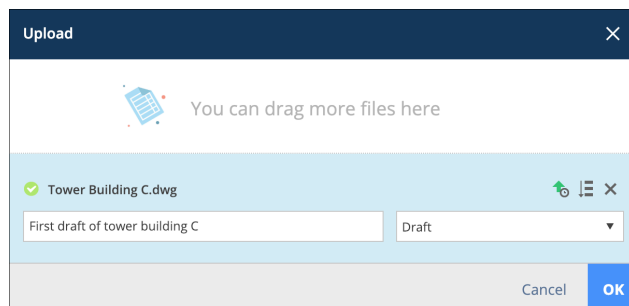

Click or drag and drop to upload a document.

- 1 Fill in the status of your document

2 Optionally add a description

☰ If you are uploading multiple files with the same status you can click this icon to fill in all document statuses of the documents underneath.

In case the folder has metadata, more fields will appear in the upload dialog for you to fill in.

The screenshot shows an 'Upload' dialog box. At the top, it says 'You can drag more files here'. Below that, there is a green checkmark and the text 'Tower Building A.dwg'. To the right of this text is a green circular arrow icon, a list icon, and a close icon. Below this is a text input field containing 'Type a description' and a dropdown menu showing 'Draft'. Underneath, it says 'Document will be renamed to Pla_HVAC_A_4.dwg'. There are four dropdown menus: 'Pla, Plan', 'HVAC, Heating Ventilation AirConditioning', 'A, Building A', and '4'. At the bottom right, there are 'Cancel' and 'OK' buttons.

Note that when you upload a document that already exists in the folder, it will be uploaded as a revision of that document.

Upload revision

The screenshot shows an 'Upload revision' dialog box. At the top, it says 'Select the file you want to add as a revision, either by clicking or by drag and drop in the upload area.' Below that, there is a green checkmark and the text 'Tower Building A.dwg (c)'. To the right of this text is a close icon. Below this is a text input field containing 'New proposal of tower building A' and a dropdown menu showing 'Proposal'. There is also a checkbox labeled 'Rename to: Tower Building A reworked C.dwg'. At the bottom right, there are 'Cancel' and 'OK' buttons.

You can add a revision using this action. Select the file you want to add as a revision, either by clicking or by dragging and drop it in the upload area.

Optionally:

- Change the original document name to: ... (only if you can edit the document)
- Replace last revision (overwrite the last revision, only for administrators when the option is set)

2.1.6 Edit

Click the Edit action to change multiple aspects of a document:

- Name (only when metadata is not used to generate the name)
- Description
- Document status
- Metadata (if you have access)



You can edit multiple document statuses at once by selecting the document first before clicking the edit action.

2.1.7 Copy

Copy the document to another folder. Only the folders you can add a new document will be available in the copy document dialog.

2.1.8 Move

Move the document to another folder. This option is only available if you have the right to delete the document. Only the folders you can add a new document will be available in the move document dialog.

2.1.9 Add to binder

You can add a document to a binder folder.

Optionally you can select a specific revision to add it in the binder. If you do not select a revision you will always see the latest version in the binder.

2.1.10 Print to PDF

Print the document or information about the document to a PDF-file. Specify the content of your PDF-file:

- Document details
- Document Content
- Binders
- Revisions
- Notes
- Notifications
- Links
- Shares
- Workflows
- Annotations

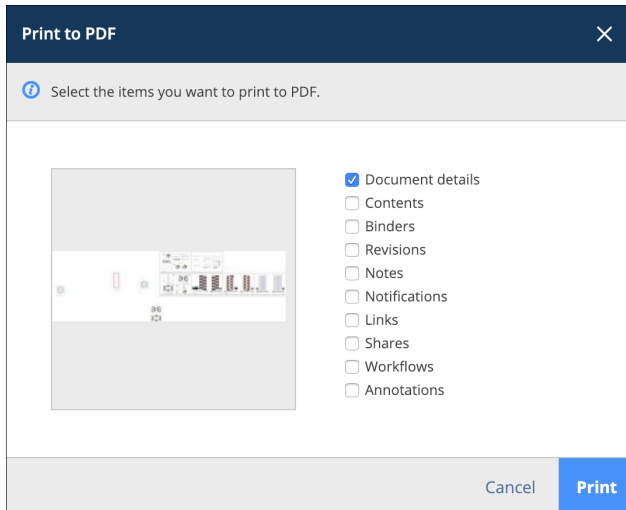

2.1.11 Delete

When you delete a document it will be stored in the recycle bin. Only the administrator can access the recycle bin and delete it definitively or restore it to the original document folder.

You can't delete a document and upload a document with the same name because the deleted document is stored in the recycle bin.

2.1.12 Attach document

Gives you the opportunity to manually upload a new document from your local machine and attach it to the document directly or link the document to another document in your project.

When linking to another document on the project the advanced options let you choose whether you want to link a specific revision to a specific revision. By default the documents are always linked to the last version of each document.

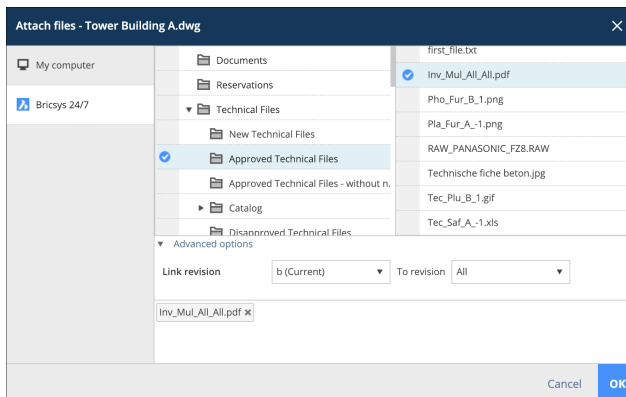

Once the document is linked you can see it in the Document inspector [on page 30](#) and in the details of the document. If it is linked to another document, you will see the link in the other document as well.

When uploading dwg files from within BricsCAD or AutoCAD with our Bricsys 24/7 connect plugin, xrefs will be linked automatically for you.



2.1.13 Public share

Share documents with people who aren't part of the project by creating a unique URL and send it to them. Everyone with this link can open the document in the viewer without them having to log in on the project.

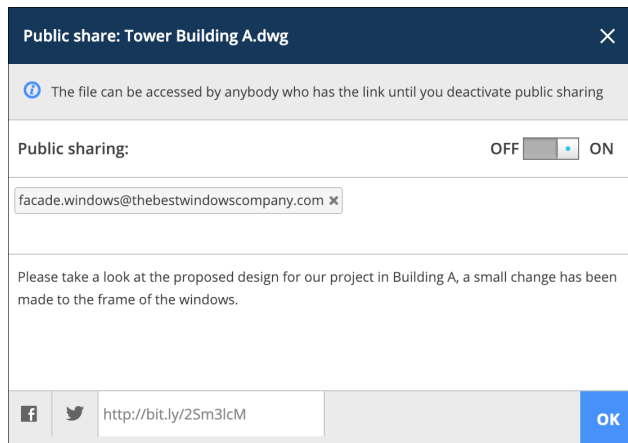

You can always turn off the share by toggling the public share slider on the top right. After you turned off the sharing, the URL link will no longer work.

Watch out: If you re-share by doing the same action, another URL will be generated, different from the old UR you generated the first time.

2.1.14 QR Code

With this action you can generate a QR-code to view the document. The QR-code will automatically link to the correct view:

- Document details
- Viewing the document in the online viewer
- Downloading the document

The user will need to log into the project and access will be checked.

2.1.15 Folder notification

Send a notification about the folder with a comment and select the Bricsys 24/7 users with access to the folder.

This notification is about the folder, not about a document. If you want to send a notification about a document, select send notification instead of send folder notification.

2.1.16 Document Details

If you click the name of the document, a window will pop up with a preview and more detailed information about the document.

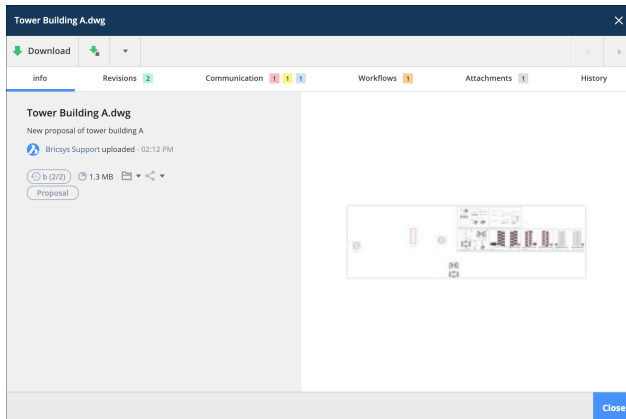

The tabs on top of the dialog group the information by category.

Info

Preview

If you click this preview the viewer will pop up (See Document Viewer [on page 12](#)).

If viewer does not open, check your browser for window blocker.

Document Details

- Name and description of the document
- Uploaded by
- Date and time of upload
- Status and size of document
- Metadata (in case the document has metadata)

Location

What is the location of the document in the project and to which binders this document has been added (See Binders [on page 39](#)).

Sharing information

Shows you to whom and by whom the document has been shared publicly.

Since the **guest user** option is no longer available, you can use the option **share**.

You will not be able to share an entire project. However, you can share a document or a folder.

In the Structure app, click on the arrow of the drop-down menu and select **share document** to give access to that document for a guest user. From the same menu, you can choose the option **share folder** to share a specific folder.

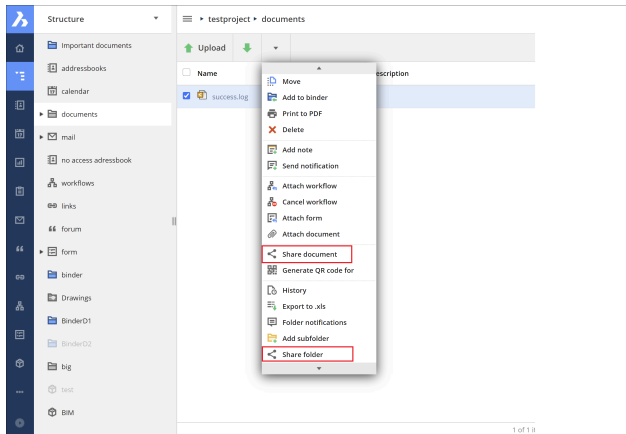

🕒 Revisions

Gives you an overview of all the revisions that a document has. Click on a revision to open the revision details in the panel on your right.

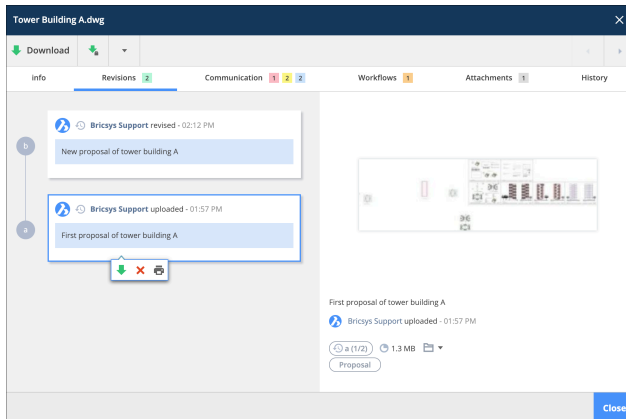

Hover over a revision to

- Download
- Print to PDF
- Delete (only if you have delete access on the document and the project administrator allowed the deletion of revisions)

Clicking on a specific revision will filter the communication and attachments in the corresponding tabs to the selected revision.

Communication

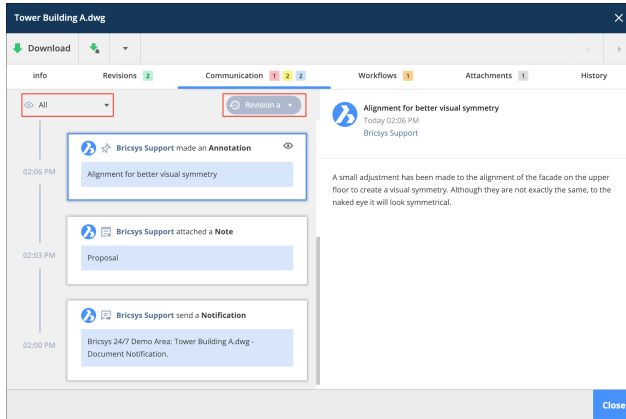

The communications panel gives you an easy overview of all the communication concerning the document. You can easily filter on the type of communication and to which revision the communication corresponds to.

Types of communications:

- Annotations
- Always apply to a specific revision of a document. Since the annotation is made within our online document viewer.
- Notifications
- Always apply to the document, independent which revision you're viewing
- Notes
- Always apply to the document, independent which revision you're viewing
- Workflow messages
- When a user executes a task and adds comments, these are stored as a workflow messages

Workflows

The workflows panel shows you all active workflows first. Via the drop-down you can also view the finished and canceled workflows attached to this document.

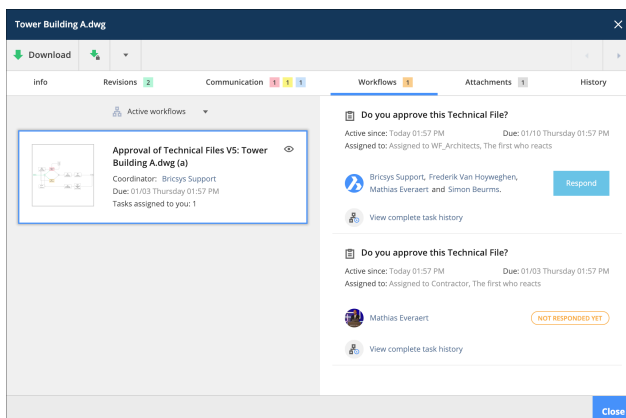

Active workflows show the active tasks, if you have an active task, the respond button invites you to execute the task.

Finished and canceled workflows show the entire workflow history.

Attachments

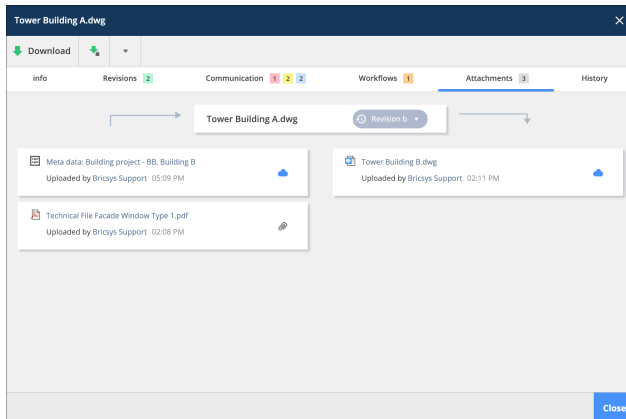

The attachments panel is divided into:

- Left side: documents and forms that are part of this document
- E.g. A technical file that belongs to a drawing
- Right side: documents that this document is part of
- E.g. This drawing (xref) is part of a master drawing

2.2 Binders

2.2.1 Overview

A binder is a folder that groups objects of different types (documents, messages, events,..) and different locations on the project.

Drawings DWG 2D		Remove from binder						Filter	Info
Name	Description	Author	Date	Status	Type	Folder			
<input type="checkbox"/> Tower Building A.dwg	New proposal of to...	Bricsys Support	Yesterday	Proposal	Document	Support			
<input type="checkbox"/> Tower Building B.dwg	Second proposal of ...	Bricsys Support	Yesterday	Proposal	Document	Support			
<input type="checkbox"/> Pla_Fur_B_2.dwg		Bricsys Support	11/05/2018	Proposal	Document	Documents			
<input type="checkbox"/> Pla_Stru_C_1.dwg (c)		Bricsys Support	11/05/2018	Draft	Revision	Documents			

The objects that are shown in the binder are links to the actual objects that are stored somewhere else in the project.

2.2.2 Different ways to use a binder:

1. Group different types of objects

You can use a binder to group different kinds of objects that are spread all over the project, for example, to prepare a meeting.

2. Give a group of users access rights to a few objects

You can use a binder to give a group of users access to a few documents. If you give these users (via a roll) access to the binder, they do not need to have access to the original object in the containing folder itself.

3. Access to documents with a certain status

Administrators can edit the binder settings and define that only certain document statuses are shown in the binder.

Important:

The binder folder is set to show documents with statuses *Approved* and *Approved with comments* only. If you want documents with other statuses to be shown, you have to change it manually in the settings of the binder folder.

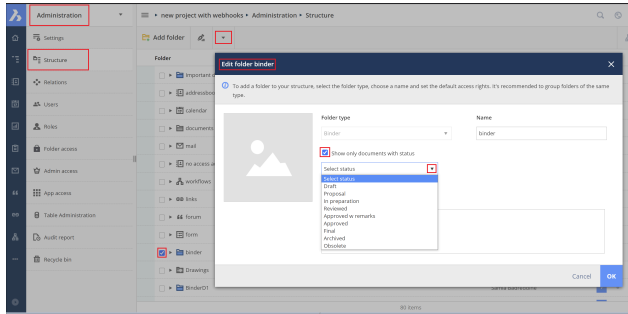

This way, you can give users access to a binder which contains multiple documents but only when the status of the document matches the filter of the binder, the document will appear.

2.3 Dashboard

The dashboard App is the central hub that monitors all project related activities for you. After opening a project in Bricsys 24/7, the Dashboard app opens.

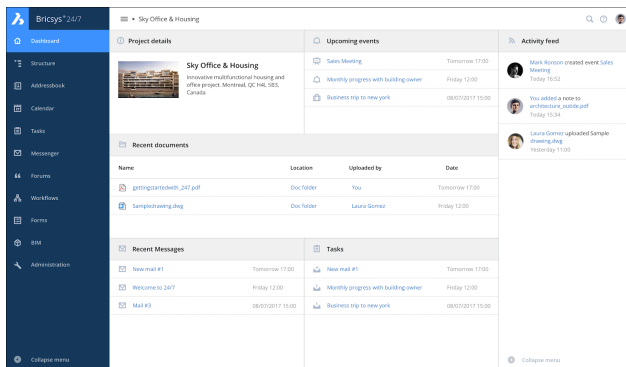

Remember that only the items you have access to are displayed.

2.3.1 Project details

Project details which have been set by an administrator of the project.

2.3.2 Recent documents

An overview of all recent documents over the last week: added, revised, moved, copied...

2.3.3 Upcoming events

The upcoming events in the coming week, as registered in a calendar within the project.



2.3.4 Recent messages

The messages of the last week.

2.3.5 Tasks

Tasks you are assigned to:

- The task must be completed within the next 7 days.
- The task is not yet completed and the end date has expired.

2.3.6 Activity-stream

A chronological view of the project activities.

2.4 Project Structure

The Structure app is a powerful document management tool. It shows all the folders and subfolders of the project you have access to.

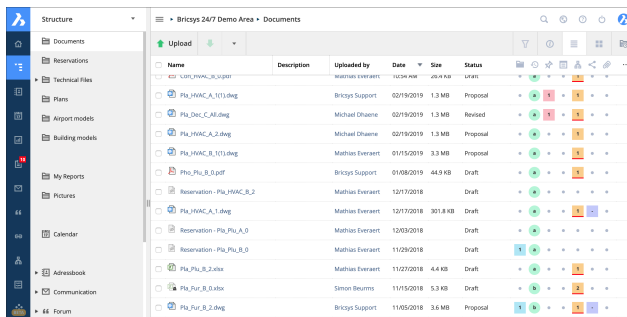

This is the most important and most frequently used app on Bricsys 24/7.

2.4.1 Document & Binder folders



The Structure app is the only app that allows you to go through your project tree and view document and binder folders.

2.4.2 Project tree

The project tree shows the folder structure as set up by the administrators of the project.

2.4.3 Folder types

There are different folder types and each folder type has its own objects and related app in the app bar.

Folder Icon	Folder Type	Content	Related App
	Document folder	Documents	Structure App
	Address book folder	Contacts and organizations	Address book App



Folder Icon	Folder Type	Content	Related App
	Workflow folder	Workflows	Workflow App
	Message folder	Messages	Message App
	Calendar folder	Events	Calendar App
	Form folder	Forms	Forms App
	BIM folder	Documents, BIM DWG and BIM IFC	BIM App
	Link folder	URL-Links	Links App
	Forum folder	Threads and posts	Forum App
	Binder folder	All kinds	Structure App

App Content

After selecting a folder, the app content will load the objects of the selected folder. Because there are different folder types in the project tree, the content will adapt to the selected folder type.

Column selector

At the end of the table headers there's a "..." icon that you can use to show or hide certain columns. When working with metadata, the extra metadata columns are displayed here as well.

2.4.4 Project info

The project information dialog gives you an overview of each folder and the possibility to download an Excel file with the documents in the entire project or selected folders.

Click the drop-down arrow on top of the folder structure and choose the option "Project Info" to open the project information dialog.

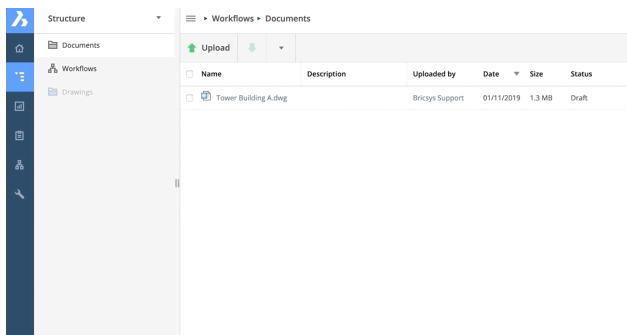



2.5 Address book App

The address book holds contacts and organizations you are allowed to see. If you have the rights, you can manage the contacts and organizations in different address books within the project.

2.5.1 Address book views

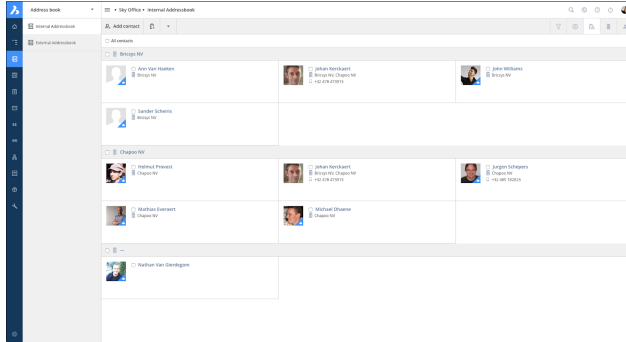

In the top right corner you can switch views. The default view of an address book is the hybrid view.

Hybrid view

It shows the organizations (companies) together with the contacts. If a contact has no organization, it will appear under the "---" organization on the bottom of the list.

Company view

The company view gives you an overview of all the organizations within the address book.

Contact view

The contact view gives you an overview of all the contacts within the address book, sorted alphabetically.

2.5.2 Actions

All the actions in this App are above the App Content.



Add contact



When adding a new contact you can choose to import an existing contact from another address book you have access to or create a new contact.

Import contacts from another address book

- 1 Fill in contact's name
- 2 Select contact
- 3 Add Contact

Create a new contact

- 1 Fill in the contact details
- 1 First name, last name and email are required fields
- 2 Add contact

Add organization

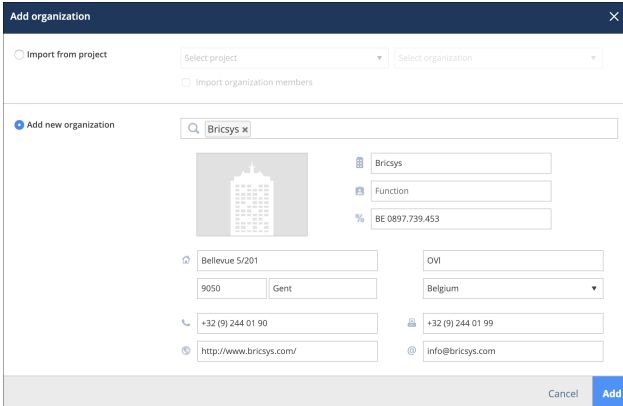

When adding a new organization you can choose to import from another project or create a new organization.

Import organization from another project

- 1 Select the project
- 2 Select the organization
- 3 Check the import organization members box if you wish to import the contacts of that organization as well
- 4 Add organization

Create a new organization

- 1 Fill in organization details or copy from an existing organization.
Only the name of the organization is a required field
- 2 Add organization

Add user

Administrators can select a contact and add the contact as a new user in the project.

2.6 Calendar

Project-specific calendars allow participants to manage, track and lock all events.

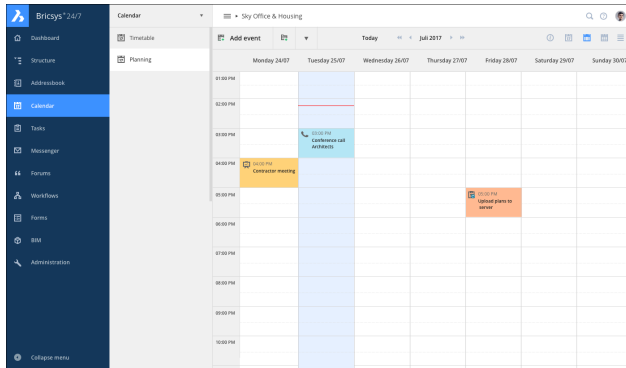

2.6.1 Add event

When clicking on the current date or any future date in the calendar, a dialog will pop up to add the new event. You can also click the action menu **Add event**.

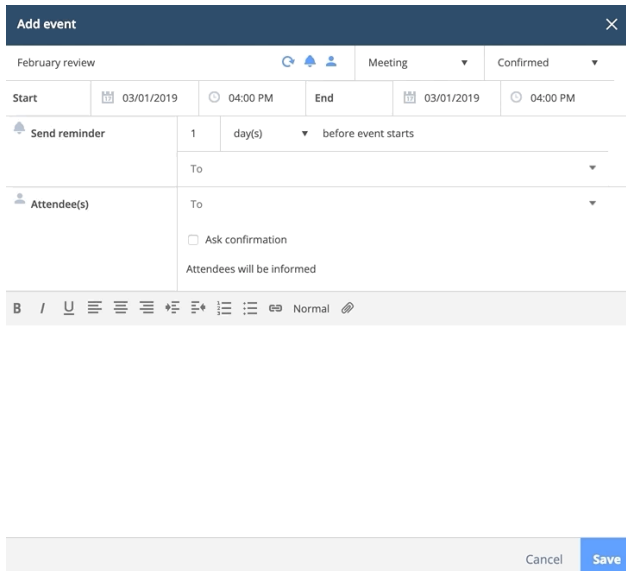

In the dialog you need to give in the:

- Name of the event
- Type of the event
- Description to the event

Add an attachment to the event

You can add an attachment to the event by selecting a document on Bricsys 24/7 or uploading a new document from your local computer.

▼ Choose a type of event

There are multiple types of events available:

- Meeting (default)



- Call
- Public holiday
- Task
- Travel
- Vacation
- Birthday

▼ **Choose status of the event**

Depending on the type of the event you chose, multiple statuses might become available:

Meeting

- Confirmed (default)
- Tentative
- Canceled

Task

- Assigned
- Completed
- Completed 75%
- Completed 50%
- Completed 25%
- In progress
- On hold
- Open (default)
- Postponed

 **Recurrent event**

If you want an event to repeat itself, you can click the recurrent event icon and select the time to repeat in:

- days
- weeks
- months
- years

And select the date that the event should stop repeating itself.

 **Add attendees**

Select the users that attend or are assigned to this event.

 **Add a reminder**

You can select to send a reminder to users before the event starts.

2.7 Reports

Important:

We are redesigning the reports app into a new workflow reporting tool.



The current report app lets you revise your tasks and do workflow auditing.

Period	01/28/2019 - 02/27/2019	All workflows	All folders	All actors
Approval of Technical Files V4	Attached to	Actor	Activity	Runtime
Approval of Technical Files V4: B...	BC_-1_Akoestiek_DR_Chapoo_Pr...	Bricsys Support, Mathias Everaert, Fred...	Approval by Contrac...	345d 4h 53m
Approval of Technical Files V5	Attached to	Actor	Activity	Runtime
Approval of Technical Files V5: C...	Con_HVAC_B_0.pdf	Bricsys Support, Mathias Everaert, Fred...	Approval by Architec...	2d 5h 24m
Approval of Technical Files V5: P...	Pla_Dec_C_All.dwg	Mathias Everaert, Bricsys Support	Rework / Disapprov...	8d 5h 12m
Approval of Technical Files V5: P...	Pla_HVAC_A_1(1).dwg	Mathias Everaert	Approval by Contrac...	8d 6m
Approval of Technical Files V5: P...	Pla_HVAC_A_2.dwg	Mathias Everaert, Frederik Van Hoyweg...	Approval by Architec...	8d 5h 14m
Approval of Technical Files V5: P...	Pla_HVAC_B_1(1).dwg	Mathias Everaert, Bricsys Support, Fred...	Approval by Architec...	43d 5h 49m
Approval of Technical Files V5: T...	Tec_Fur_B_4.xls	Bricsys Support, Mathias Everaert, Fred...	Approval by Architec...	1d 2h 45m

2.7.1 Tasks

Take a look at the MyTasks app which replaced the old tasks overview from the reports app.

2.8 Messages

Effective communication is the key to successful management. With our 'Messages' app you will be able to manage communication effectively and efficiently.

You can send both private and public messages to other users. The other user(s) must also be included within the project. To make communication more efficient all messages; notes, annotations, notifications, workflow, etc. are stored in the same app.

When you create a new message in the 'Messages' app your recipient(s) receives an email with a link that transfers them directly to the 'Messages' app where they can read the content of the message. To receive messages in the 'Messages' app you must have access to the app (access to the app can be granted only by a project administrator).

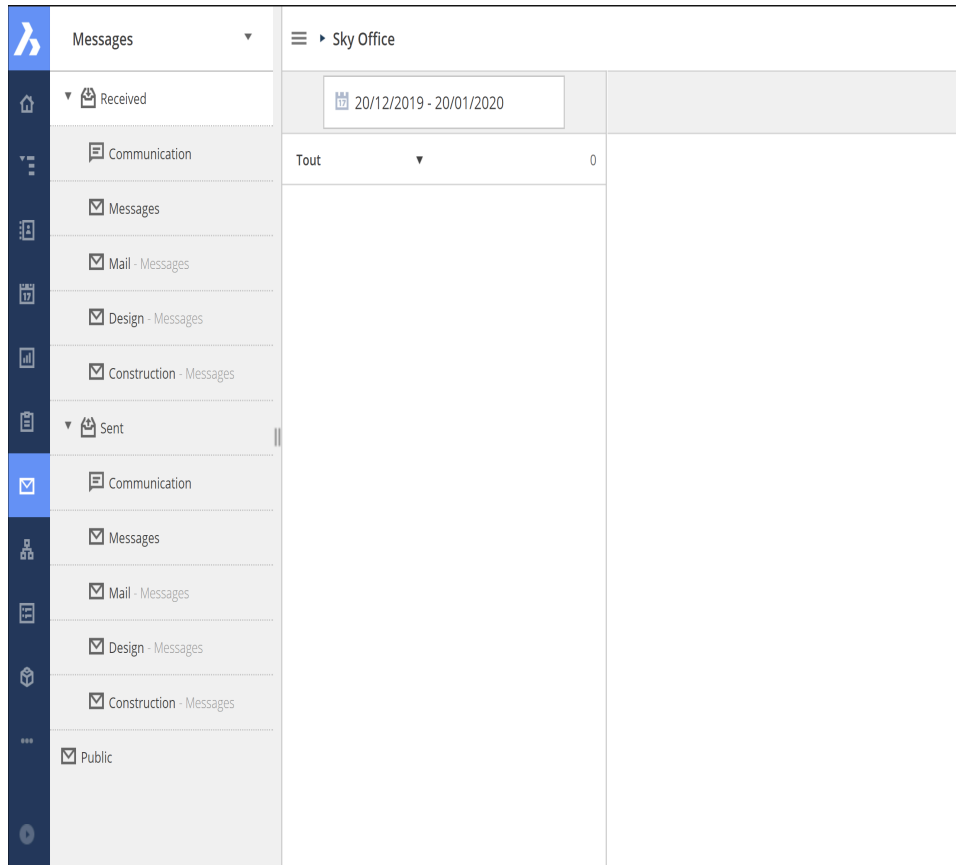

2.8.1 New message

Create a new message as you would an email in your favorite email program.



Messages

Sky Office

New message

Inbox 0

- Received
 - Communication
 - Messages
 - Mail - Messages
 - Design - Messages
 - Construction - Messages
- Sent
 - Communication
 - Messages
 - Mail - Messages
 - Design - Messages
 - Construction - Messages
- Public



New message ✕

To Cc Bcc ▾

Subject

B / U Normal

Tower Building A.dwg ✕ Tower building B.dwg ✕

Cancel Send

Note: Only the users with access to the 'Messages' app can be added as recipients.

You can also attach files (the attachment icon). Upload from your computer or select an existing document from Bricsys 24/7.

2.9 Forum

The forum app is ideal to have a discussion about a certain topic.



The screenshot shows a forum interface with a sidebar on the left containing navigation icons. The main content area is titled "Discussion Forum" and shows a thread titled "External glass requirements" with 2 subscribers. The thread is started by John Williams at 12:34. The discussion includes three posts:

- John Williams (Today 12:34):** Thanks for your suggestions. We decided to stick to the same glass for the whole building. It will have UV protection and $k=1.1$.
- Anna Haek (Today 12:30):** Hi John,
The fifth floor houses some datarooms. I recommend extra UV filtering and maybe $k=1.0$ to make the cooling more efficient.
Anna
- John Williams (Today 12:24):** Hello all,
Please let me know if you have any specific requirements for the outside glass of the building. The default will be HR+ $k=1.1$, reflective coating.
If you require extra features like sound resistant, extra strenght, ... let me know as soon as possible.
John.

2.10 Links

Need to share external references with other members of the project? Use the link app to share webcams on construction sites, external references...

The screenshot shows the "Links" application interface. It features a sidebar with navigation icons and a main area titled "Bookmarks" with a "New link" button. Below the button is a table listing saved links:

Name	Link	Description	Created by
Building Research Institute	http://www.brri.be/		Jurgen Schepers
Chapoo public site	https://www.chapoo.com/		Jurgen Schepers

At the bottom of the main area, it indicates "2 items".

2.11 Workflows

2.11.1 What is a workflow

Workflows let you design, edit and manage automated processes (e.g. approvals of documents). A workflow on Bricsys 24/7 contains activities and transitions.

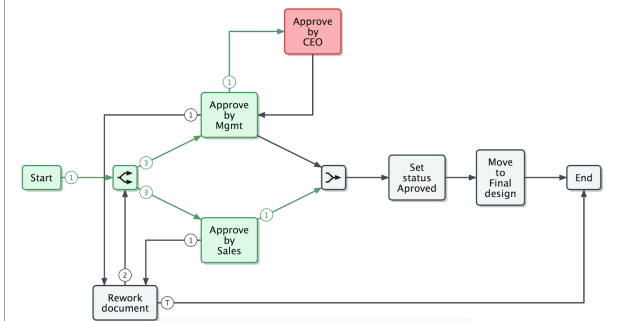

2.11.2 Obsolete workflows

Obsolete workflows are workflows that cannot be used anymore.

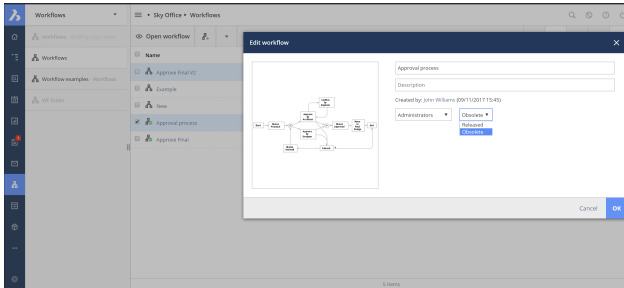

Take into account that active workflows that become obsolete stay active until they are finished or canceled.

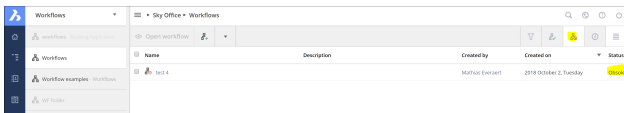

Name	Description	Created by	Created on	Status
Test 4		Michael Bencart	2018 October 2, Tuesday	Active

2.11.3 Create workflow

Take a look at the [setting up workflows](#) article to create and manage workflows.

2.12 Forms

The forms app lets you build a form, fill in a form and search through its records. A form is a pre-structured “file” that gives a user the possibility to add information in a structured way. Once a form is created, a user can fill in a form and a record will be created and saved on Bricsys 24/7.

There are 3 ways of using forms.



2.12.1 Metadata

Let a user fill in or select pre-structured information about the document when uploading a file on Bricsys 24/7. Without noticing it, the user can or has to fill in a form during upload. Once the user filled in the form and uploaded the document, a record of the form will be saved and attached to the document.

Example "Building Metadata"

When a user uploads a document, extra fields are shown under the description box. In this case the user has to select the:

- Document type:
 - Contract
 - Plan
 - Invoice
 - Picture
 - Other
- Discipline
 - Decoration
 - Electrical
 - HVAC
 - Safety
 - Structural
- Building
 - Building A
 - Building B
 - Building C
- Floor
 - -1
 - 0
 - 1
 - ...
 - 4

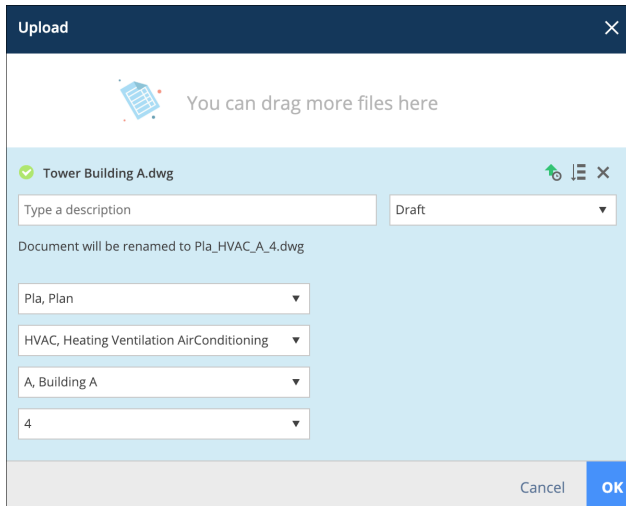

Where can you view the metadata:

- document details
- document list by enabling the document columns (see [document folder](#))
- form

Benefits of Metadata

1. Advanced search

Search in the advanced search on the filled in forms to find a document. For example:

Search for all electrical plan on the third floor without knowing where exactly the plan is stored on Bricsys 24/7, you can easily find it.

2. Filter on metadata

Metadata is visible in the document folder using the column selector. Use the filter button to search for Plans by filling in 'Pla' (for example).

3. Automatically generate a name

Optionally generate a name for the document based on the filled in the form. This gives your documents a structured name following the naming convention for your project. All documents will be named correctly according to your naming convention.

4. Create reservations

Create reservations for documents to be uploaded. When metadata is used to generated a name, you are able to create reservations which are empty documents to be filled in by the user.

An extremely useful tool in your document planning. Make sure all desired documents, plans are delivered.

2.12.2 Attachment

Instead of adding a note to a document, a user could attach a form (with pre-structured information) to a document to give a comment in a structured way. Once the user filled in the form a record of the form will be created and attached to the document.

Example "Change request"

A user can fill in or select an existing change request and attach it on a document.



Benefits of attaching a form to a document

1. Add additional information in a structured way

2. Search through the records

Search through the records of the filled in form in the form viewer.

2.12.3 Database

Fill in a form to build a database in a structured way on Bricsys 24/7.

Example "Investment demand"

Users can fill in the investment demand form in the Form App. The responsible for the investment demands can now search through these records and make better decisions about the investment.

<input type="checkbox"/>	Total price of investment request (€)	Building	Description of demand	Date of Demand	Do you approve?	Approved / Disapproved by	Name Demander	...
<input type="checkbox"/>	5,250	BC, Building C	Usage of M15 graded ...	04/04/2017 09:21 ...	Approved	Erik Rodriguez	Mark Jefferson	•
<input type="checkbox"/>	24,055	BB, Building B	Change steel structure...	03/02/2018 11:18 ...	Disapproved	Sven Anderson	Michael Jones	•

Benefits of using a form to build a database

1. Search through the records

Search through the records of the filled in form.

2. Export the data

Download the data in an Excel list to further filter and generate reports with the data.

2.12.4 Form viewer

Click on a form to open the form viewer. You can add or delete records depending on your access rights and search through the records of the form.

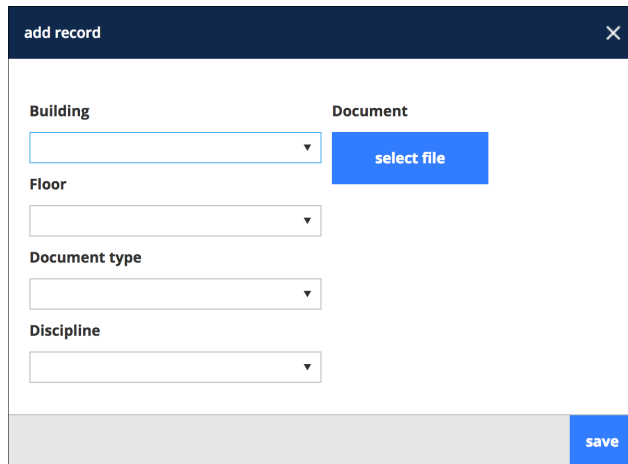

In order to add a record:

- 1 Select 'Add record'
- 2 Fill in the form
- 3 Select 'Save'
- 4 A record will be added and saved

In order to delete a record :

- 1 Select a record (If you see the record this means it is selected at that moment)
- 2 Select **Delete record**

In order to link records:

- 1 Select a record
- 2 Select **Link**
- 3 Choose the form
- 4 Select the record you want to link it to

2.13 BIM Model Manager

Within the BIM app you can easily share your Building Information Modeling (BIM) designs with your extended team - engineering contractors, construction professionals, building owners and operators.

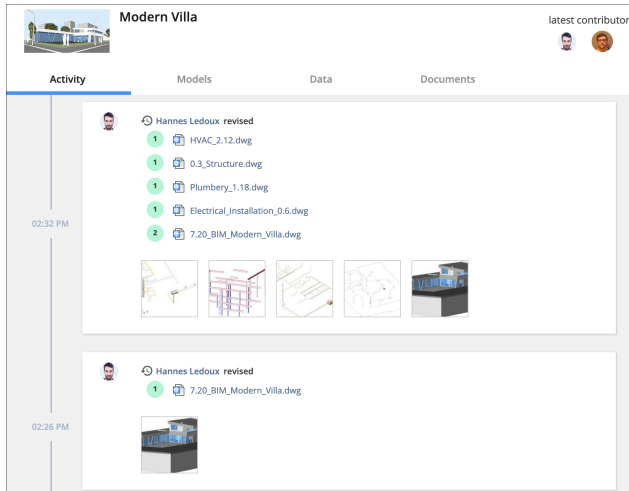

2.13.1 Centralize, store and manage your BIM

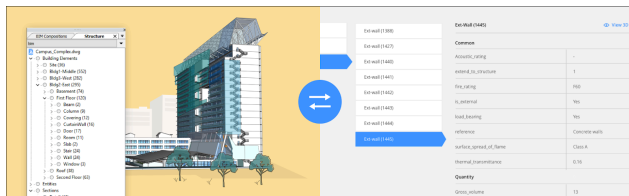

Bricsys 24/7 handles projects with vast amounts of BIM data and all associated documents. 24/7's model server manages all of the information that comprises a construction project. You can query, merge and filter your view of the BIM-model depending on your individual needs.

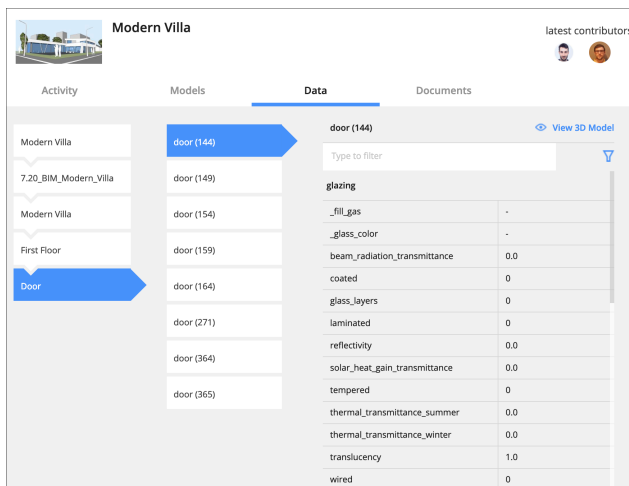

2.13.2 Upload from BricsCAD with Full XREF management

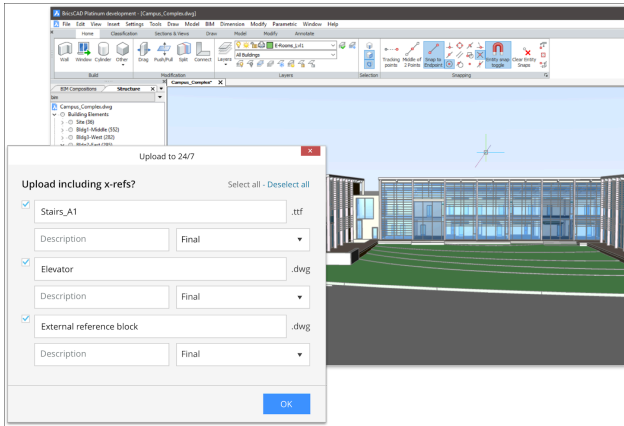

When serving a BricsCAD BIM model using external references, 24/7 will recognize and automatically manage the links between the files. A direct connection to 24/7 is available inside of BricsCAD and BricsCAD BIM.

2.13.3 3D Viewer: View and explore your BIM

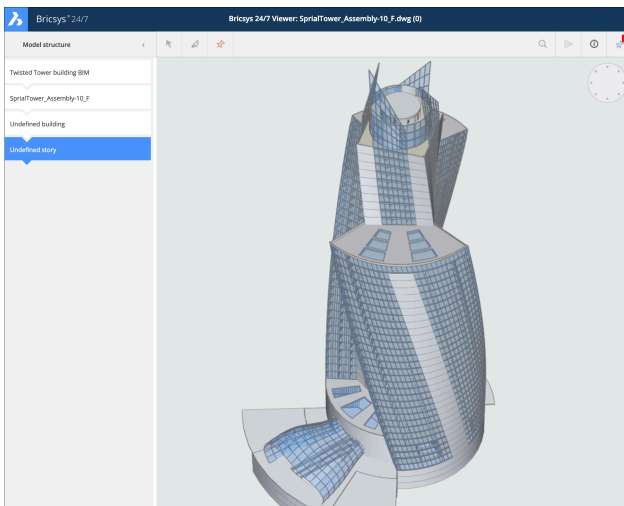

Download and view BIM designs in your browser, without installing any software. Explore, view, annotate and slice your 3D models interactively in the cloud.

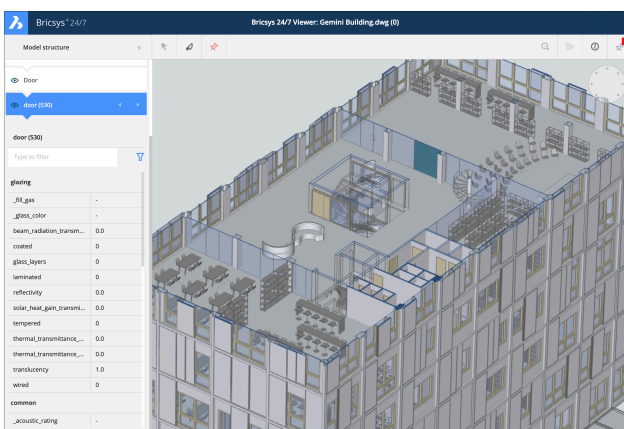



2.13.4 IFC

Bricsys 24/7 also provides full Industry Foundation Classes (IFC) support. IFC allows the accurate transfer of BIM data across multiple applications programs, and between disciplines.

We support IFC2x3 (coordination view 2.0).

2.14 Relations

Define new relations, edit and delete existing ones. A relation is a tree structure that can be used as a field within a form in order to get a structured overview of your data.

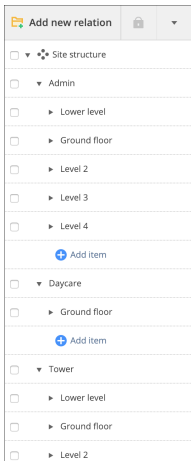

2.14.1 Add relation

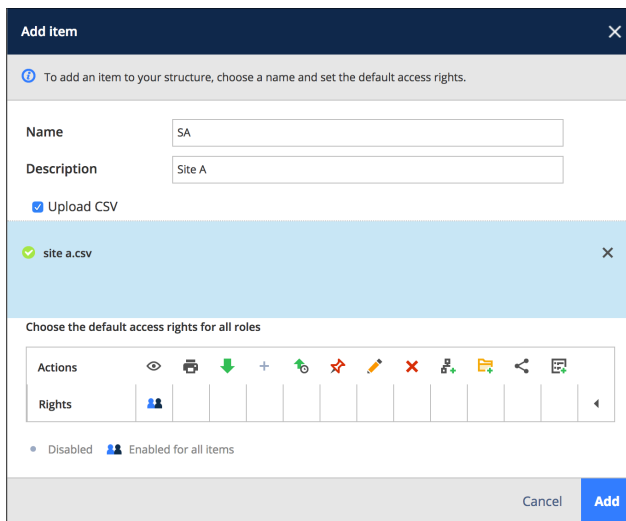

Name

When creating a new relation, you need to define the name of your highest level. That's the relation name users will always see first. The root element of the tree.

When using a relation field in a metadata form, the name will be used to generate the document name.

Please note that using **special characters** in relation fields can cause errors when using the same relation field in order to rename documents via metadata.



Description

Additionally, you can add a description to describe in more detail what it's about. This comes in very handy when you work with coded values like "BA, Building A" where "BA" is the actual name and "Building A" the description.

CSV

In case you already have the structure defined in a spreadsheet, you can easily upload the structure to Bricsys 24/7 by exporting it to a CSV file.

UTF-8 encoding

Be aware that the system will process your data in UTF-8 format. Make sure when exporting your CSV that UTF-8 is the chosen encoding. If you see strange characters in your relation after you uploaded the CSV, your encoding is probably not set correctly.

Format

In order for the system to correctly create your relation you need to follow a simple set of rules:

- Each line can only have one new level
- After each new level, you can add a description (not required)
- The highest level may or may not be defined

Example CSV:

SA	Site A		
SA	BA	Building A	
SA	BA	FL1	Floor 1
SA	BA	FL2	Floor 2

Example CSV without repeating previous levels:

SA	Site A		
	BA	Building A	
		FL1	Floor 1
		FL2	Floor 2

Example CSV without defining the highest level "SA, Site A" and without repeating previous levels:

BA	Building A	
	FL1	Floor 1

	FL2	Floor 2
--	-----	---------

All of the above examples will have the same result:

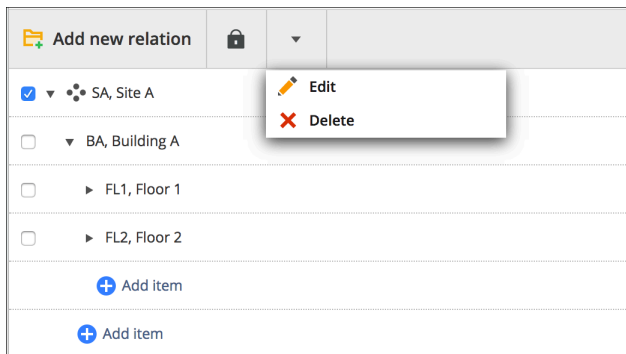

2.14.2 Access

You can set role access for each level in the relation by going to the folder access in administration or by selecting a relation level and clicking the access icon in the top menu.

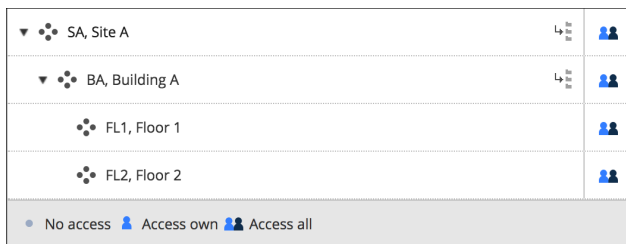

2.15 Transfer Tool

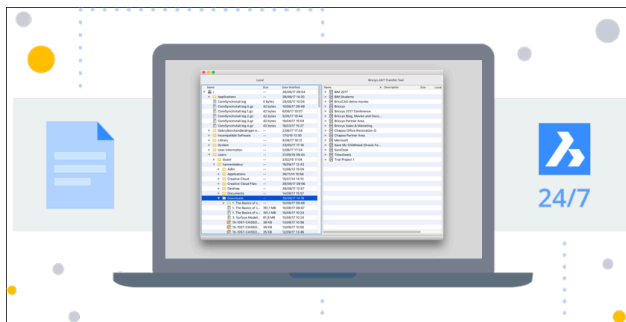

The Bricsys 24/7 Transfer Tool is a local desktop application with a few extended Bricsys 24/7 functionalities that eases the use of Bricsys 24/7. [You can download it here.](#)

- Download and upload multiple documents
- Upload a folder or a folder structure from your device to Bricsys 24/7
- Download folders / projects from Bricsys 24/7 to your device
- Open a document from Bricsys 24/7
- Synchronization

2.15.1 Download and upload multiple documents

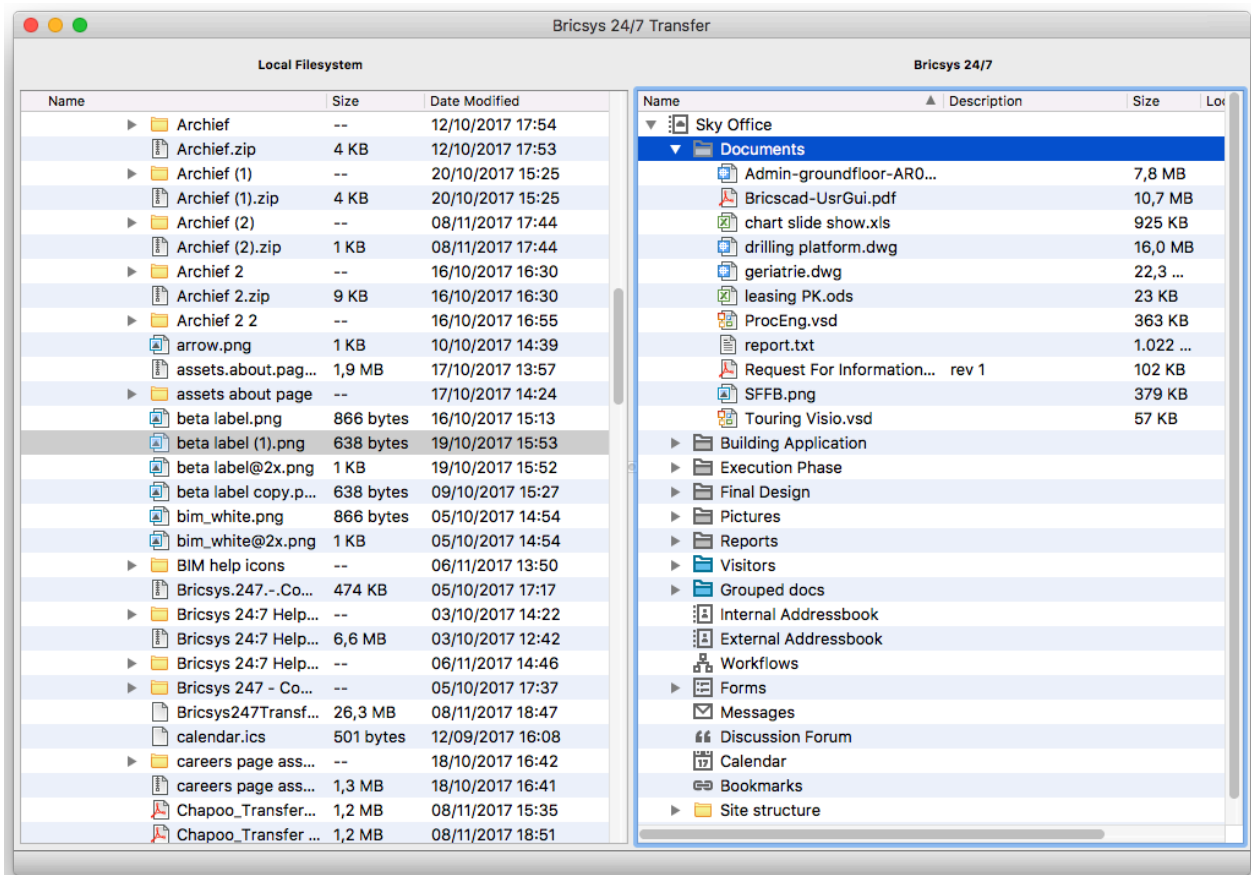

The Transfer tool allows you to transfer documents between your local file system and the Bricsys 24/7 Service. The split screen user interface allows you to upload or download documents through simple drag and drop.

2.15.2 Upload folder or a complete folder structure to Bricsys 24/7

Via a simple drag and drop you can copy a folder or a folder structure (with or without documents) Bricsys 24/7. This way you can easily setup a Bricsys 24/7 project based on a folder structure on your device.

2.15.3 Download folders from Bricsys 24/7 to your device

Via a simple drag and drop you can download a folder or a folder structure from Bricsys 24/7 - optional with the documents - to your device. This way you can easily download all documents from the Bricsys 24/7 project to your device.

2.15.4 Open a document



Name	Description	Size	Loc	Name	Description	Size	Loc
▼ Sky Office				▼ Sky Office			
▼ Documents				▼ Documents			
Admin-groundfloor-AR0...		7,8 MB		Admin-groundfloor-AR0...		7,8 MB	
Bricscad-UsrGui.pdf		10,7 MB		Bricscad-UsrGui.pdf		10,7 MB	
chart slide show.xls		925 KB		chart slide show.xls		925 KB	
drilling platform.dwg		16,0 MB		drilling platform.dwg		16,0 MB	
geriatrie.dwg		22,3 ...		geriatrie.dwg		22,3 ...	
leasing PK.ods		23 KB		leasing PK.ods		23 KB	
ProcEng.vsd		363 KB		ProcEng.vsd		363 KB	
report.txt		1.022 ...	●	report.txt		1.022 ...	●
Request For Information... rev 1		102 KB		Request For Information... rev 1		102 KB	
SFFB.png		379 KB		SFFB.png		379 KB	
Touring Visio.vsd		57 KB		Touring Visio.vsd		57 KB	

The Transfer tool makes it possible to open a document from Bricsys 24/7 with a software on your device. This way you can change the document immediately and upload it directly to Bricsys 24/7 as a revision. When you double click on a document in the Bricsys 24/7 structure (right side of the Transfer tool) a local document will be saved on your device and will be opened with a software on your own device. Now a green dot will appear next to the Document name.

A dot indicates that there is a local copy of the document from Bricsys 24/7 available on your device. A green dot indicates that the Document which is stored on your local device is exactly the same document as the document on Bricsys 24/7.

An orange dot indicates that the Document which is stored on your local device is different from the document on Bricsys 24/7.

If you open a document through the Transfer tool, then you change it and save it, the green dot will change into an orange dot. As mentioned before, this means that the document on my local device differs from the document on Bricsys 24/7. Once the dot is orange (differs from the document on Bricsys 24/7) you can choose to upload the changed document as a revision of the original document on Bricsys 24/7. You can perform this by right-clicking on the document (in the transfer tool interface) and by selecting the "upload as revision" action.

2.15.5 Synchronization

It's possible to save your downloads as synchs. When downloading a folder click the "save this transfer as synch" option to remember this download.

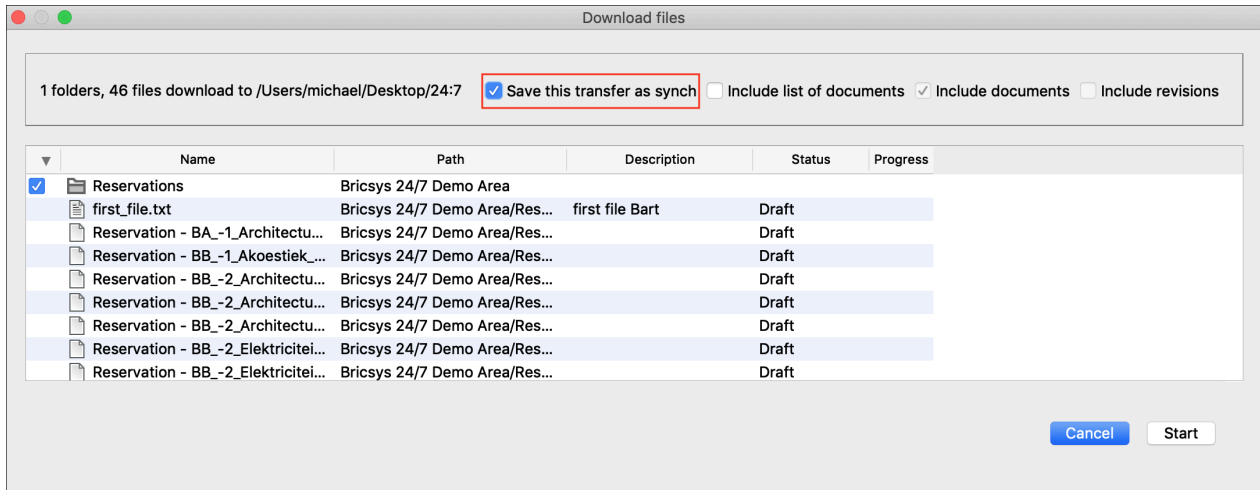

After the download is done you can revise the saved downloads in the "Synchs > Synchs overview" menu. Easily start saved downloads (synchs) by clicking the "Synchs > Start synch" action to automatically download the changes from Bricsys 24/7 to your local device.

2.15.6 Downloads

- [Uploading documents with metadata guide](#)
- [Quick guide for using synchronization in Bricsys 24/7 Transfer](#)
- [Metadata template](#)



3. Managing Projects

3.1 Setting up a project

To get up and running with a project, you need to take the following steps:

- 1 Add project
- 2 Add folder structure
- 3 Add roles
- 4 Add users

3.1.1 Add project

After logging in the project, the select screen appears without projects.

New project

Click the **Add** button to create a new project. Fill in the project name, details and country in which the project will be executed.

Copy project

When you need to manage multiple projects, most of them will have the same settings and structure. Creating an empty template project in which you set up the folder structure, roles, forms and workflows is a good way of working. This way, you set it up once and copy the project for each new project you need to set up.

If you already have an existing project, you can create a copy of it based on the original one and select the options that you would like to copy in the new project (for example forms and metadata).

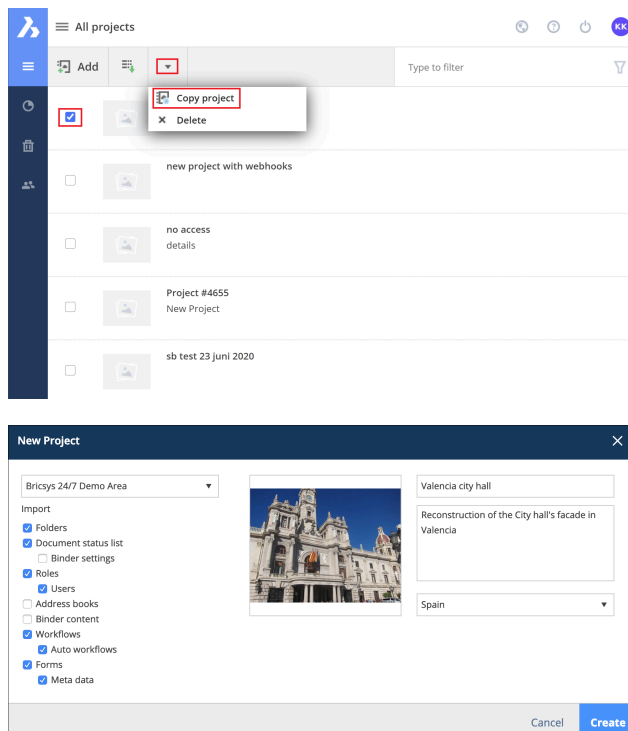

Only the customer admin can create a new project or copy an existing one. A customer can have multiple customer admins that are managed by the Bricsys 24/7 team.



Note: when you copy a project, only the folder structure will be copied but the documents will not be transferred. If you also need a copy of the folders with documents included, you will have to select the folders and documents manually and use the copy action. It is also possible to copy the documents using the transfer tool.

Copying projects with forms and metadata:

The forms can be copied together with the project. However, since the documents are not copied automatically, the form records will not be transferred either. This does not apply to the links between forms and folders as these ones will be copied. For example, when you copy a project and you check 'Forms' and 'Metadata', the links between the forms and the folders will be copied. This means that, if you upload a new document in a folder with a form attached, you will be asked to fill in the metadata.

3.1.2 Administration app

Once the project is created and you enter the project, click on the wrench icon in the app bar on your left to go to the administration app.

3.1.3 Settings

The Settings category lets you edit the project settings, document settings, calendar settings, administrator settings.

Document settings

In the documents settings you can define how revision numbering will be displayed in the project.

Single version

By default, single revisions are used. Choose the option you wish to use.

Major / minor version

Select the checkbox **Enable major/minor versioning of documents** in order to work with a dual revision number. This is a useful way to track the progress of a document. Each major version can represent a milestone the document has reached.

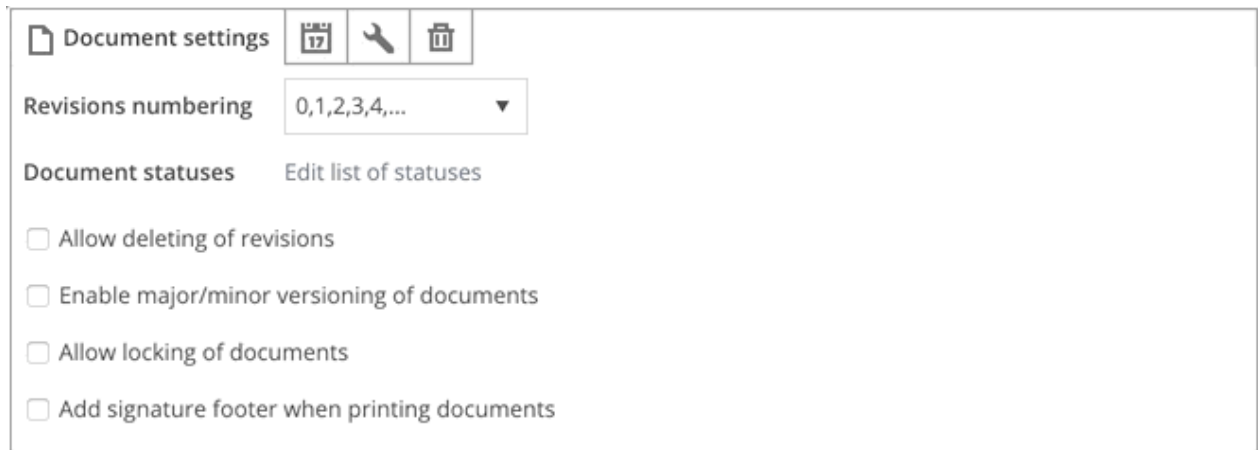

3.1.4 Structure

In the structure setting you can create the folder structure for the project. Bricsys 24/7 gives you 100% freedom to create a folder structure depending on your company's needs.

You can manually add folders by clicking the **Add folder** action or use the transfer tool to easily copy an existing folder structure from you local computer to Bricsys 24/7.

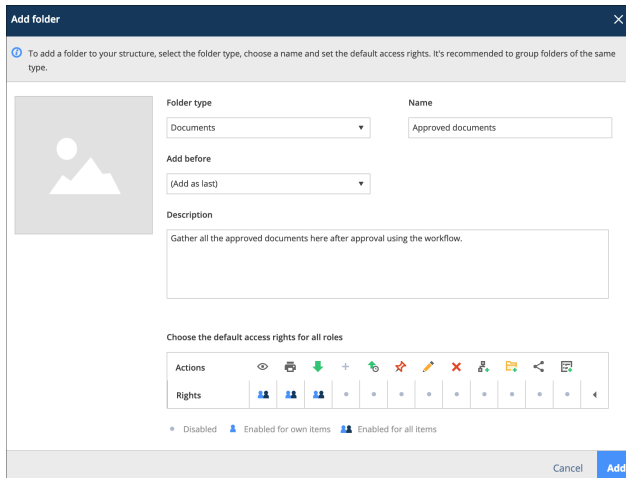

Folder options

- Folder type

Each folder type represents its own app in the side bar. Only Document and Binder apps can be viewed within the Structure app. All the other folders can be viewed within the Structure App as well as their own App.
- Default access rights

Setting the default access rights enables you to quickly set the same access for all the existing roles the moment you create a folder.

Remember that each folder type represents a different app in the app bar.

Roles

After setting up the project structure you need to define roles. A role groups project members together making it easy to differentiate them in the project. Typical examples of roles are “Administrators”, “Architects”, “Engineers”, “Contractors”...

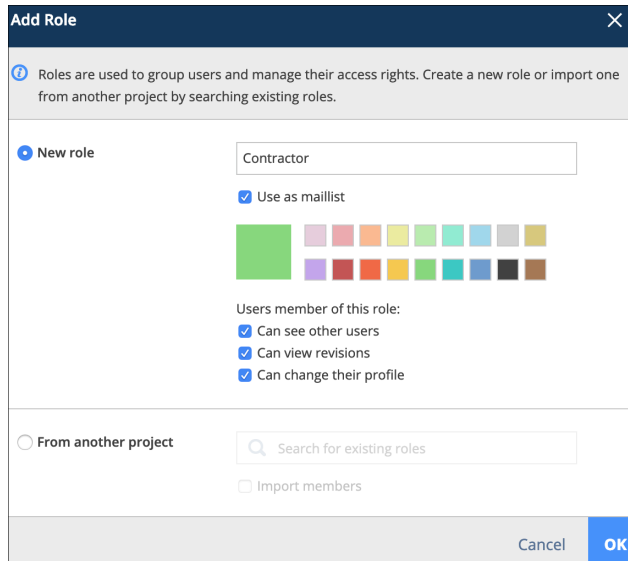

Role options

- Use as maillist
This enables to select the role when sending a notification, a message... as the recipients. All members of the roles will be selected and can be unchecked individually by the user.
- Color
The color is used in the document viewer. By giving a different color to the roles, annotations within the viewer are easily distinguished and make it clear who made the annotation; the architect, engineer...
- See other user
If a role cannot see other users, the members of the role will not be able to send notifications to other project members.
- View revisions
Enable a role to view the revisions of a document. When unchecked, only the last revision of the document will be visible.
- Change their profile
We strongly recommend to enable this setting so users can change their personal information and preferences.

3.1.5 Folder Access

Once the folders and the roles have been set up, it's time to set up the access. The Folder Access category by default shows the folder structure and a role in the drop-down above the structure.

Easily switch to roles view by selecting the option **By Role** in the drop-down above.

Access inspector

The access inspector on the right shows if the access is set or not. There are two types of access: view all, view own. View own means that the user can only access the items that he or she is author of.

Depending on the type of folder, not all access types might be available.



Click in the matrix to set or remove a specific access. Use the toggle buttons on top to set the same access over all the folders, the toggle buttons on the right to set default access. The top right corner toggle button allows you to toggle all the access.

For each folder with subfolders the **apply to subfolder** icon lets you easily copy the same access to all the subfolders.

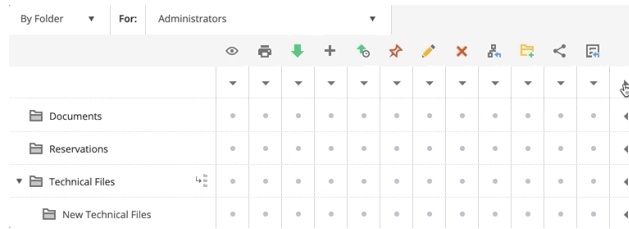

Save the changes before you leave the access category.

3.1.6 Users

Now that a project has folders, roles and access we can add users. The **Users** category lets you add users to the project.

Click the **Add user** action to add a user. Always add users by adding the **email address** of the user. In case the user has already access to Bricsys 24/7 in another project, the user will be shown in the search results. Otherwise you can create a new user.

After adding the user, select the roles the user is part of. A user can be part of multiple roles which means the access will be the consolidated access over all the roles. If the project has an address book folder you can choose to add the user to the address book.

Invitation

The last step is to send an invitation. We highly recommend to add a personal message so the user knows who's sending the invitation and the reason why.

The user can setup the password by clicking the **set or reset password** link in the invitation email. An existing user can log in with the email address and the existing password.

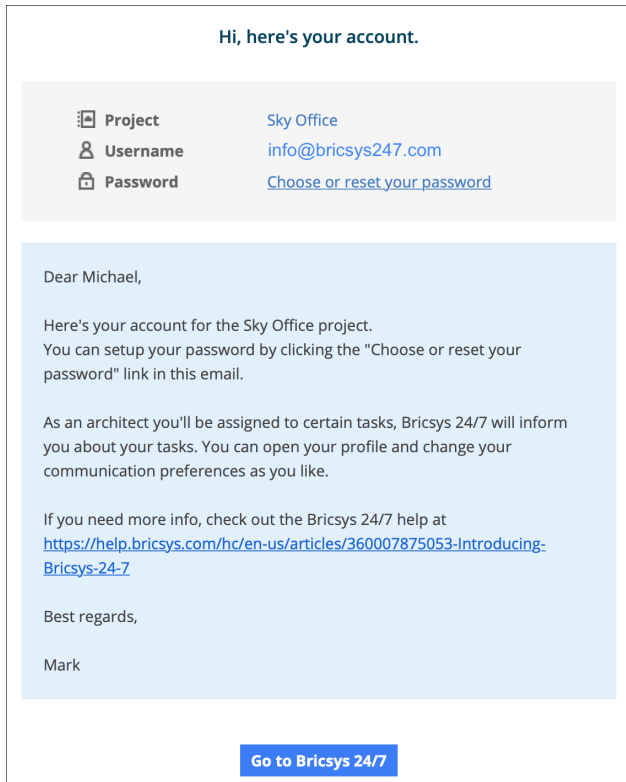

3.2 Setting up workflows

Workflows are a powerful way of automating processes within Bricsys 24/7. Typically it's used to approve documents.

In this section we'll get you started with workflows by creating a workflow in the editor, releasing it and attaching it to a document or a folder in case you want to start a workflow automatically when a new document is uploaded.

Follow these steps to successfully create and manage workflows in your project.

- 1 Add workflow folder
- 2 Add workflow
- 3 Edit workflow
- 4 Release workflow
- 5 Attach workflow
- 6 Reassign task
- 7 Cancel / delete workflow
- 8 Delete user

3.2.1 Add workflow folder

Make sure your project has a folder of type Workflow and you have access to the workflow folder. Once this is setup, the Workflows app will become available in the app bar on the left.

Once the workflow folder has been created, open the workflow app and select the created folder.

3.2.2 Add workflow

 In the workflow folder, select the **Add workflow** action.

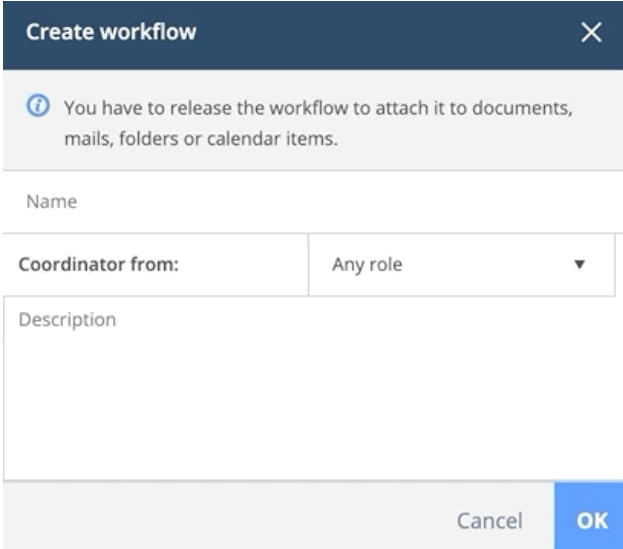

- 1 Fill in the name
- 2 Fill in the description (optional)
- 3 Select a coordinator role (every workflow has a coordinator)
- 4 Click the OK button to save the workflow and open the editor

Please note that a workflow name has to be unique within the project. If the system tells you that the workflow name already exist, check if the obsolete workflows and recycle bin in case you don't see the workflow.

If the workflow editor does not open, please check your browser and make sure popups from Bricsys 24/7 are allowed.

3.2.3 Creating a new workflow

Create a workflow in five steps:

1 Add activities

Activities are tasks that will be executed manually or automatically by the system. All automatic tasks use the coordinator's access rights to execute the task.

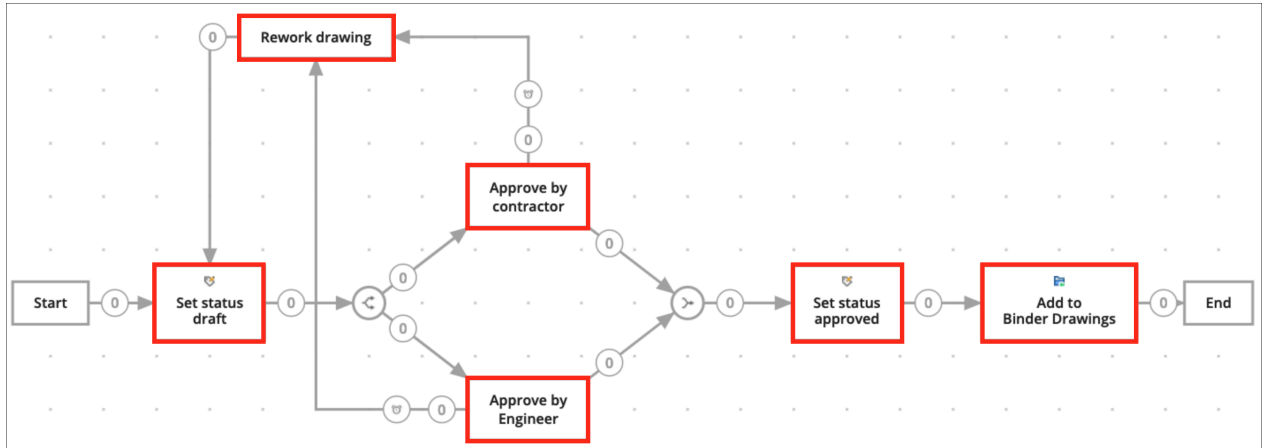

a Add an activity to the grid

Click on the activity icon and then somewhere on the grid to add an activity.

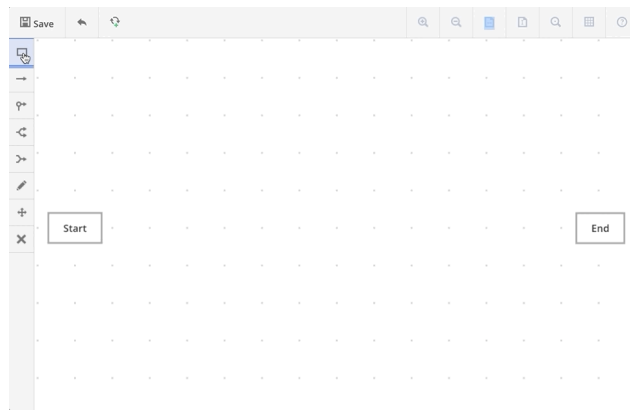

b Fill in the activity settings

i Choose an action: (the type of the activity)

Automatic activities that will be executed using the coordinator's access:

- Set the status of a document
- Copy the document to another folder
- Move the document to another folder
- Add the document to a binder folder
- Remove the document from a binder folder
- Promote last revision to major version

Manual activity:

ii Assign a task to somebody

A user of the assigned role will get a question and has to answer with some proposed answers. (The proposed answers will be the names of the transitions that are leaving the activity)

Activity options

(a) Fill in question

Fill in the question of the task, for example: Do you approve this document?

(b) Choose who needs to react

Choose a **role** that has to do the task.

(c) Specify who has to do the task

The actor of the previous activity or the coordinator has to select who will be the

actor of the this activity.
 The first to react. Everyone of the role will get the task but as soon as someone did the task, the others do not have to do it anymore.
 Everyone: Everyone of the role will get the task and everyone has to do the task.

iii **Choose a reminder and/or a deadline (optional):**

- Send a reminder

After the selected time, the selected person will get a reminder of its task

- Act within

If the selected person doesn't react in time, the workflow will continue. You can select which transition will be followed in the transition overdue section.

4 **Add start / synchronize parallel paths (optional)**

In case multiple activities need to start or come together, use the start parallel and synchronize parallel paths.

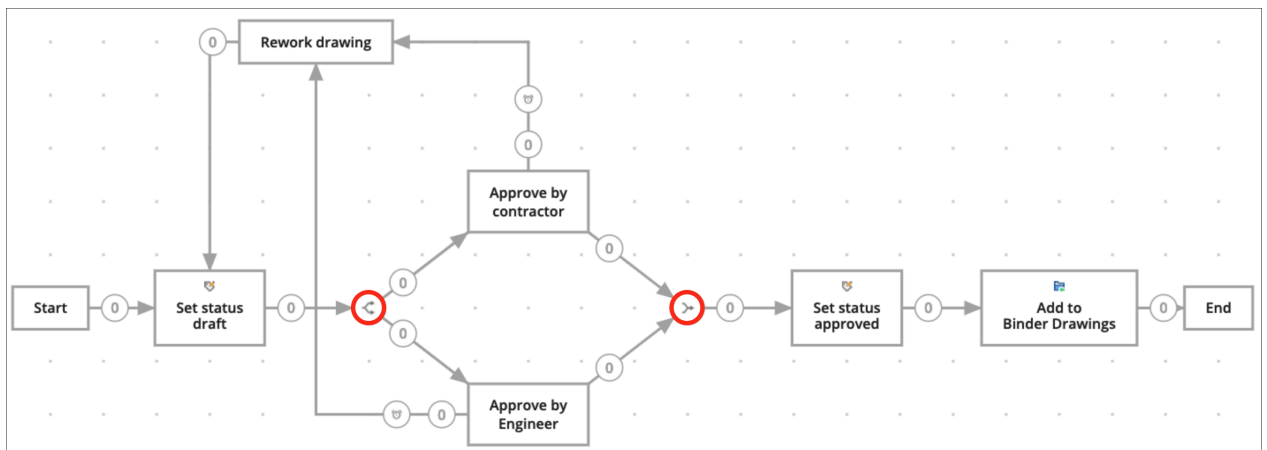

a **Add Start Parallel Path**

If the path of your workflow has to split, you have to add a start parallel path.

For example

If multiple parties

b **Add Synchronize Parallel Path**

If you want 2 or more paths to come together, add a synchronize path. The synchronize path will wait for all incoming transitions to be activated before continuing the workflow.

For example

If both contractor and engineer approve the document, continue the workflow and set the status approved.

5 **Add transitions**

Transitions are the arrows that connect activities and make it possible for the workflow to follow a predefined path.

Outgoing transitions from manual activities are the answers that a user can select when executing the task. An outgoing transition can have multiple answers. In Bricsys 24/7 we refer to answers as states.

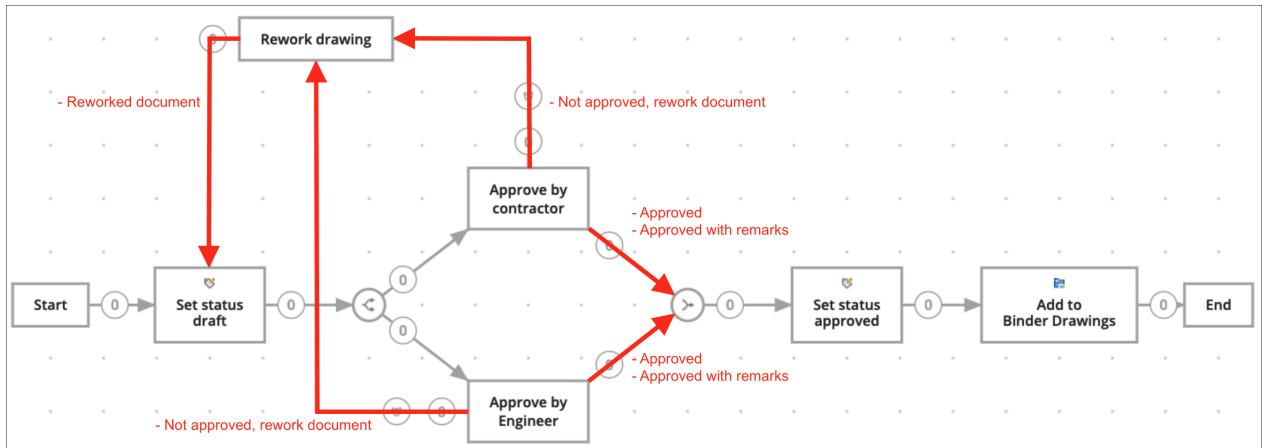

a Create a transition from one to another activity

- Click the activity the transaction has to start from.
- Click the activity the transition has to go to.

b Transition settings

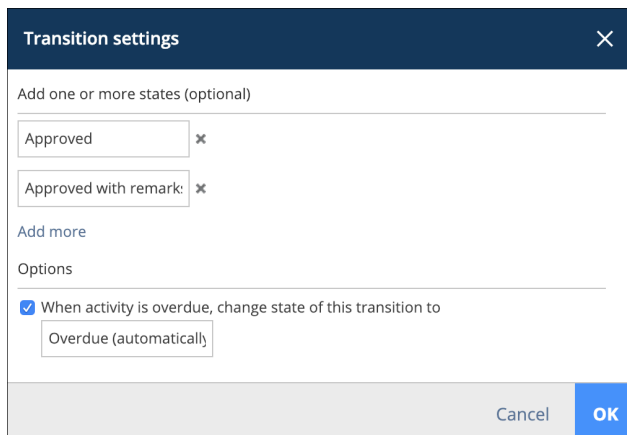

Every transition needs at least one status. The system will automatically create put "Done" as the default status.

- Add one status (for manual tasks only)
 - If you're adding a status to a transition, the actor of the activity has to respond to the activity before the workflow will continue. The status that is filled in the transition will be the proposed answer for the actor. When the actor selects this proposed answer the workflow will continue.
 - For example after a task-activity (See Add activity > Assign task to somebody). The actor will get a task. That actor now can select the proposed answer (status you filled in, for example I approve). If the actor now selects this proposed answer, the workflow will continue via this transition to the next activity.



- Add more statuses (for manual tasks only)
 - If you want several proposed answers leading to the same activity. (For example: I approve, I approve with remarks).
- c **Transition Overdue (optional)**
 - When an activity is overdue, change the state of this transition to: "Overdue (automatically)" is the default state, but you can change this to your own state.
 - If you selected that the actor of the task has to act within a certain time, you can mark the transition to be followed once the deadline has passed.
 - For example if the actor doesn't react within 2 weeks, the workflow will continue to the next action via this transition.

Transition states need to be unique. There cannot be two outgoing transitions that have the same state. Eg. The answer "Approved" and another transition with the same answer "Approved". This would make it impossible for the workflow to choose the correct path.

6 **Move / Edit your workflow (optional).**

Move the activities to the correct position to have a better overview of your workflow.

7 **Save the workflow**

After you created all your activities and transitions, do not forget to save your workflow in the workflow editor before you close the editor.

3.2.4 **Releasing a workflow**

In order to make the workflow active, it has to be released first.

Edit

Change the status in the edit workflow dialog.

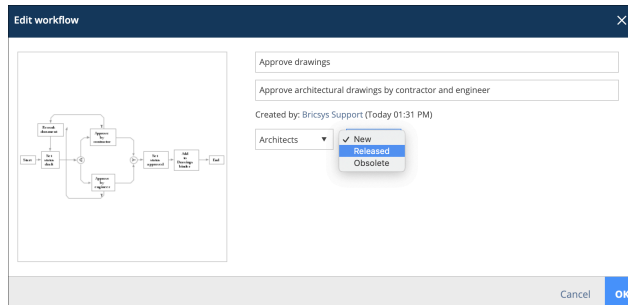

Release action

Use the Release workflow action in the action menu.

Once a workflow is released and in use, the workflow cannot be changed anymore. In case you want to edit the workflow you'll need to create a copy of the workflow first.

3.2.5 Attach workflow

In order to use a workflow you need to attach it first. You will need 'view' rights on the workflow folder to be able to see the workflow in order to attach it to a document. There are two ways to attach a workflow to a document:

Manually attach a workflow to a document

If you are granted "attach workflow access" by the administrator you can manually attach a workflow to a document.

- 1 Select a document and click attach workflow
- 2 Choose which workflow you want to attach, who will be the coordinator and give the workflow a name
- 3 Attach the workflow

Once the workflow is attached to the document it will start automatically. Note that only workflows that are released can be attached.

Attach a workflow to a folder

If you want to automate all the documents in a folder with a workflow you need to attach the workflow to the folder. (See **Administration App > structure**)

Once the workflow is attached to the folder, it will start for every new document that is uploaded.

3.2.6 Reassign task

It happens all the time, a project member got sick, is on leave or left the company but still has tasks assigned to be executed.

As an administrator you can easily reassign tasks of a user in **Administration > Users**. Select the user and choose the "reassign tasks" action from menu above.

Select another user in the project to transfer the tasks too. Note that the user needs to be in exactly the same roles as the current user assigned to the tasks.

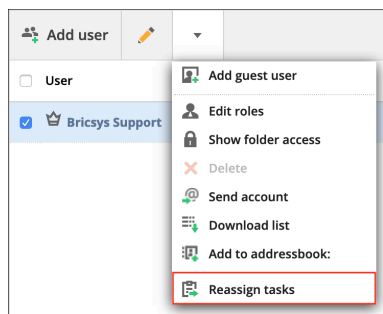

3.2.7 Cancel / delete workflow

It is possible to either cancel or delete a workflow. If you cancel it you will basically put it on hold and it can will be possible to activate it again if needed. However, if you delete it, it will be transferred to the recycle bin.

- 1 To cancel a workflow:
 - As coordinator or admin: you need "view" access to the document.
 - As owner: you need "edit" access to the document.

You will find the **'Cancel'** option in the drop down menu of a document that the workflow is attached to. Since canceling is related to editing rights, please note that the "cancel" option is not associated with adding rights.

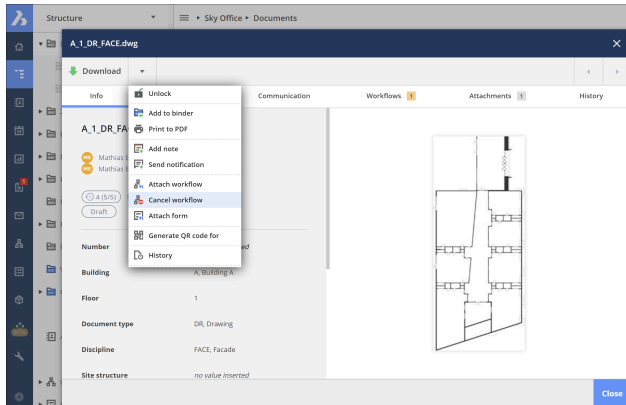

2 To delete a workflow:

There may be no instances attached to the workflow and you will need deleting rights to the document in order to be able to delete the workflow.

As long as you have the appropriate rights you can delete the workflow by clicking on "Delete" in the drop down menu of the workflow.

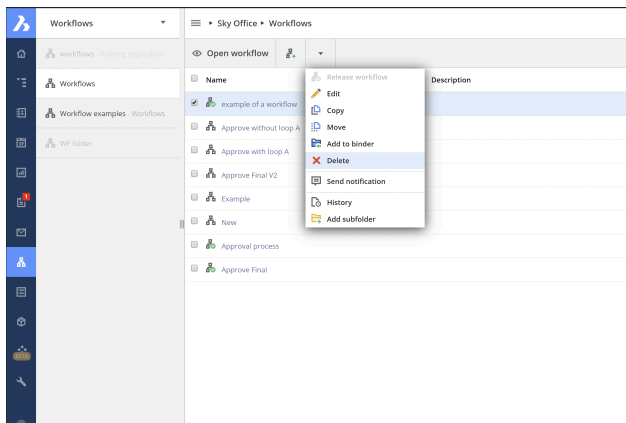

3.2.8 Delete user

In order to delete a user from a workflow first, you will need to reassign all tasks to another user who has at least the same role membership. Anyone who is in role 'administrator' can forward all tasks of that user to someone else. Only then it will be possible to delete the user. Once the coordinator is removed anyone can become a coordinator, as long as he has the same access rights. It is up to the administrator to choose a new coordinator.

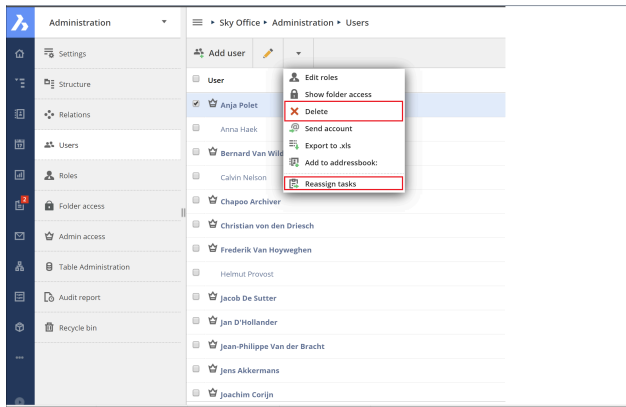

3.3 Setting up metadata

Forms are a great tool to save all kinds of data in Bricsys 24/7. One of the most common use cases is metadata, extra information to a document in order to easily group documents together and search on that data throughout the project.

Follow the next steps to successfully create and manage forms in your project.

- 1 Add form folder
- 2 Create form
- 3 Set Access
- 4 Attach form
- 5 Reservations

Once the metadata is set up you can upload a document with metadata, use the filter in the documents app or the advanced search to find the documents based on the metadata throughout the project.

3.3.1 Form folder

Make sure your project has a folder of type Form and you have access to the form folder. Once this is setup, the Forms app will become available in the app bar on the left.

3.3.2 Create form

In the form folder, click the **Add form** action to open the form editor. Edit the name of the form on the upper left corner by clicking the name.

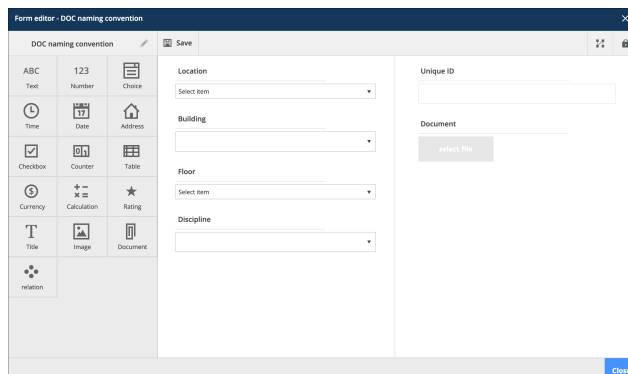

On the left panel multiple types of form fields are shown. The top right corner lets you toggle how users tab from one field to the other.

Form fields

The form fields are the elements that contain data. Simply select the desired form field and drop it on the right side. The form itself has two panels. You can drop the form fields on either side.

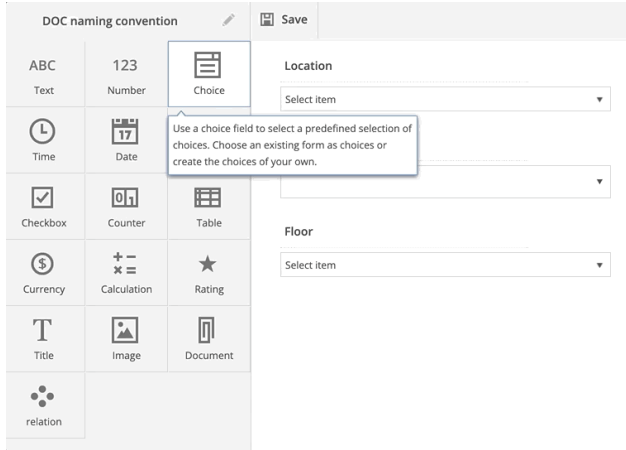

Once a form field is dropped, the settings of the field can be adjusted. Each field has its own settings. Click the wrench icon to reopen the settings for the form field.

Choice field

A choice field is a drop down that shows options a user can choose from. You can add the choices yourself manually. Each choice consists of a name and a description. The name is required and will be used in case you use metadata to define the document name.

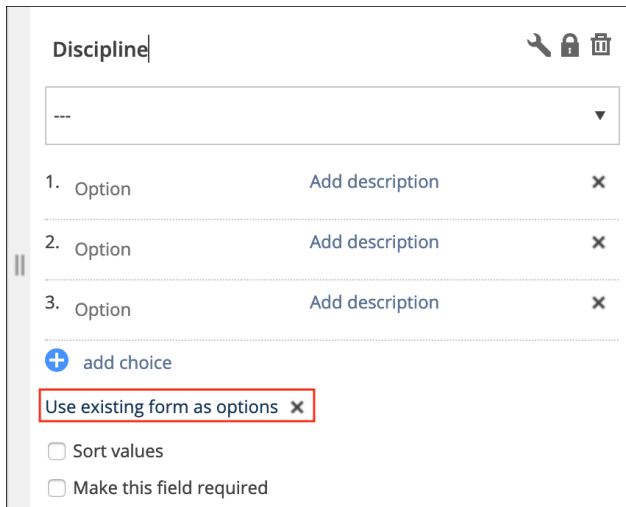

Instead of adding the options yourself manually, you can **Use existing form as options**. By clicking the link a new dialog pops up and asks you which form you would like to use and which fields you want to view in the drop-down.

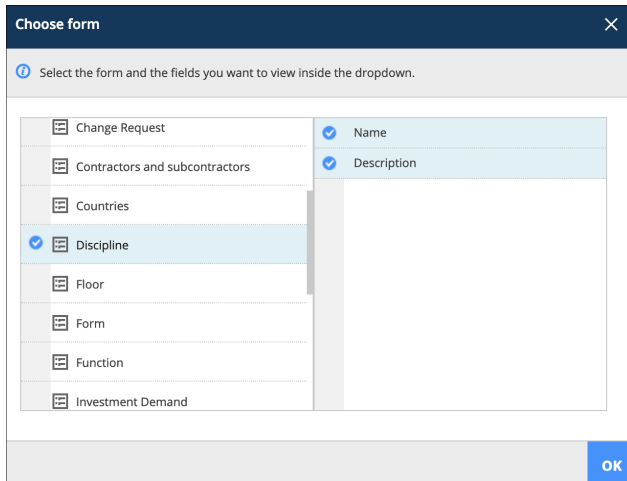

Unique counter field

This field makes it possible to add a counter at the end of your document name, should you chose to rename the documents based on the metadata input.

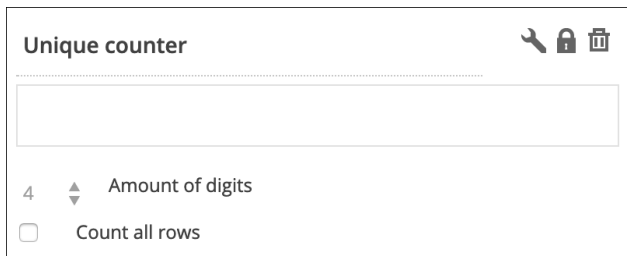

It will search for the amounts of rows that already contain the same data. If none have the same data, the number will be 1. If there are already 2 rows with the same data, the number will be 3.

You can chose the amount of digits will be used: 1 to 10 maximum. Selecting 4 digits will turn number "1" into "0001". A document name might be: PL_HVAC_0001.dwg

Document field

If you want to work with metadata, make sure you add a document field to the form. In case you want to have different metadata for each revision of a document, check the "Link to a revision" box.

3.3.3 Form access

As an administrator you can define the access on a form by going to **Administration > Table administration** . Just like the folder access you can set the access per role and per form.

For:	Architect A				
▼ Building Metadata					
Type document					
Discipline					
Building					
Floor					
Document					



There is only view all access in forms. Open the form to view the form fields and set individual access on the fields.

Now access on a form might be a bit tricky at first, take a look at the Table Administration entry to have a better understanding.

Add access

When a role has add access and the form is used as metadata, the form fields with add access will be shown in the upload dialog.

Edit access

When a role has edit access and the form is used as metadata, the form fields with edit access will be editable if the user can edit the document.

3.3.4 Attach form

Once a form has been saved you can attach it to a document or to a folder. If you want to work with metadata, the administrator of the project needs to attach the form to a folder in **Administration > Structure**.

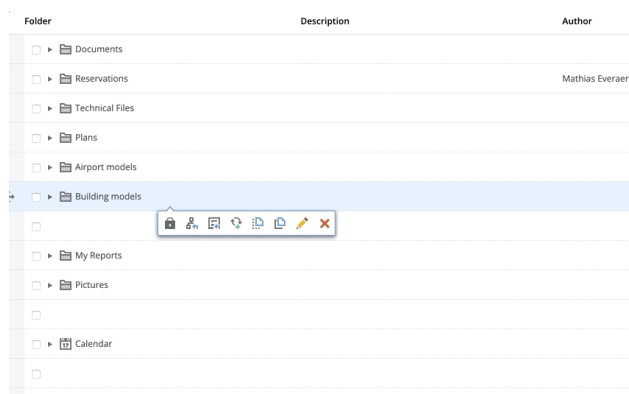

Rename uploaded documents

You can rename documents based on the data filled into the form. This is ideal for everyone looking to have a structured name for their documents. Renaming also enables you to add reservations.

The administrator can also define default metadata per folder so a user doesn't have to pick all the values each time a new document gets uploaded.

Default values

You can predefine per folder metadata values. This lets you set values so a user doesn't have to select it again and only needs to fill in the necessary metadata.

3.3.5 Reservations



It's not uncommon that document managers already have an entire list of documents to be produced for the project. With reservations you can add empty documents that are a placeholder for the real document.

In order to work with reservations, the attached form needs to have the **Rename uploaded documents based on the field's content** option checked.

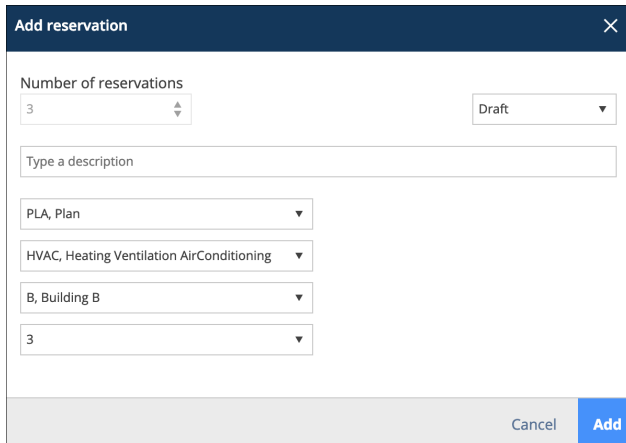
Open the document folder and select the **Add reservation** action from the menu. You can add up to 50 reservations at once. In the example below we are adding 3 reservations:



This results in 3 reservations:

Name	Size	Status	Type document	Discipline	Building	Floor
 Reservation - PLA_HVAC_B_3_0003		Draft	PLA, Plan	HVAC, Heating Ve...	B, Building B	3
 Reservation - PLA_HVAC_B_3_0002		Draft	PLA, Plan	HVAC, Heating Ve...	B, Building B	3
 Reservation - PLA_HVAC_B_3_0001		Draft	PLA, Plan	HVAC, Heating Ve...	B, Building B	3

The real document can be added as a revision which will replace the placeholder. The name of the reservation will be updated from "Reservation - PL_HVAC_B_3_0001" to "PL_HVAC_B_3_0001" after adding the document.

This way you can easily follow up the missing documents.

3.3.6 Advanced search

Now that you are using metadata within your project you can easily search on that metadata. Go to the advanced search by entering the search field in the top right corner and clicking the "Advanced Search" button.

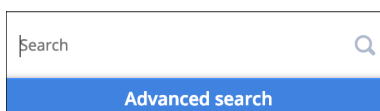

Click the **metadata** radio button to search on metadata, chose the form and add your criteria. In this example we search for all HVAC plans on the third floor of building B.

Bricsys 24/7 will search the entire project for documents that match your criteria and return the ones you have access to.



Advanced search ✕

Documents + Add more

Communication + Add more

Meta data

Type document

Discipline

Building

Floor

Cancel Search

3.3.7 Filter

Within the document app you can filter on the metadata using "&" and "|". The following example returns all the documents that match the criteria "PLA", "HVAC", "B", "3".

Upload		PLA & HVAC & B & 3								
Name	Size	Status	Type docu...	Discipline	Building	Floor				
<input type="checkbox"/> Reservation - PLA_HVAC_B_3_0003		Draft	PLA, Plan	HVAC, Heat...	B, Building B	3				
<input type="checkbox"/> Reservation - PLA_HVAC_B_3_0002		Draft	PLA, Plan	HVAC, Heat...	B, Building B	3				
<input type="checkbox"/> Reservation - PLA_HVAC_B_3_0001		Draft	PLA, Plan	HVAC, Heat...	B, Building B	3				

Use the ... button in the top right of the documents table to toggle the metadata columns in the documents app.



4. Administration

4.1 Overview

Only the administrators of a project can see and use this App. This administrator app gives administrators the possibility to set up and manage the project environment. The app is divided in different categories.

Settings

Fill in or edit the basic information of the Project, ask for support and change project settings.

Structure

Add or edit the project structure (project tree).

Relations

Add or edit relation structures.

Users

Invite users and assign them to their corresponding roles.

Roles

View, add or edit roles and their specifications.

Folder access

View, add or edit access rights to roles for folders.

Admin access

Specify to which sections an administrator has access.

Table administration

Change access rights for forms.

Audit report

Search through every Action / Object / User in the activity log of the project.

Recycle bin

Restore deleted objects / folders /... from the recycle bin to your project or decide to delete them definitely.

4.2 Settings

The admin can fill in or edit the basic information of the project, change project settings or ask for support.

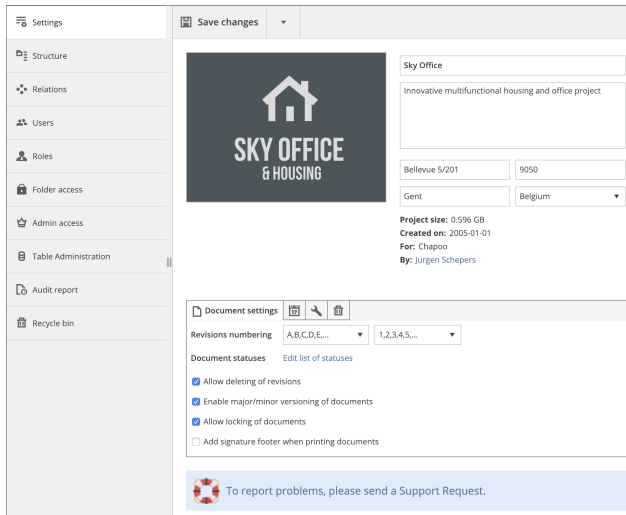

4.2.1 Basic project information

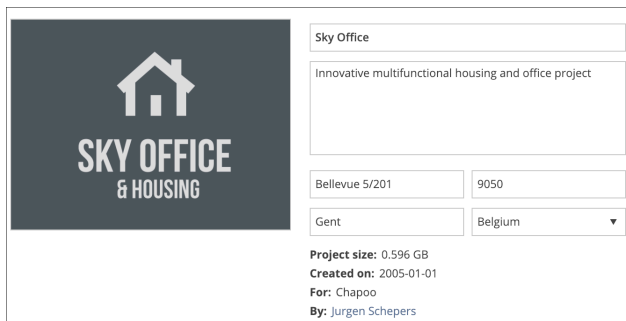

This section allows you to fill in

- Name of the project
- Description of the project
- Address of the project
- Picture of the project

4.2.2 Document settings

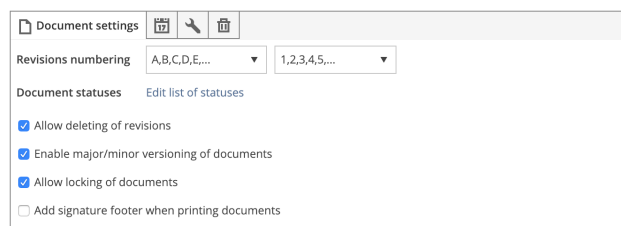

This section allows you to define how documents are treated in this project by defining revision numbering, statuses...

Revision numbering

By default revision numbering consists out one letter or number. If you enable the **major/minor versioning of documents**, two drop-downs will become visible.



The one of the left is the major version and the on the right is the minor version. The setting you see in this example will generate document revisions like this:

- A.1
- A.2
- A.3
- B.1

Edit document statuses

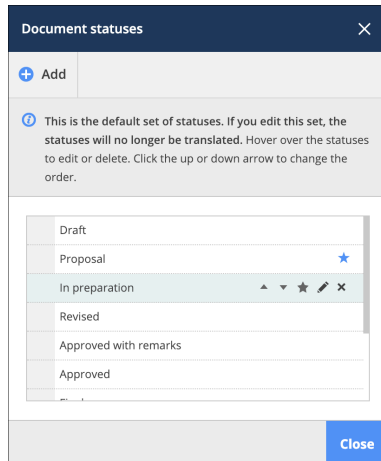

Bricsys 24/7 comes with multiple predefined statuses that are translated automatically to the user's language. However it is possible to add new statuses, edit the existing ones and make a status a default status.

The order of the statuses in this list is how they will be shown in the drop-down when uploading a new document.

★ Default status

You can set a default status by clicking the star icon. When uploading a document, this will be the selected status by default.

Allow deleting of revisions

Allow users who can delete the document to delete a specific revision. Note that a document always needs at least one revision. If you want to delete all revisions, you need to delete the document.

Enable major/minor versioning of documents

Lets users promote a revision to a new major version. This is a very handy feature that allows you to mark certain stages the document has passed through.

Allow locking of documents

Allow users to download and lock a document. A locked document cannot be moved or edited. It can be unlocked an administrator or the user that locked the document or by uploading a new revision of the document.

Add signature footer when printing documents

This will add an extra line in the footer of each document that is printed to PDF:

Printed by Firstname Lastname (date)



4.2.3 Time and date setting

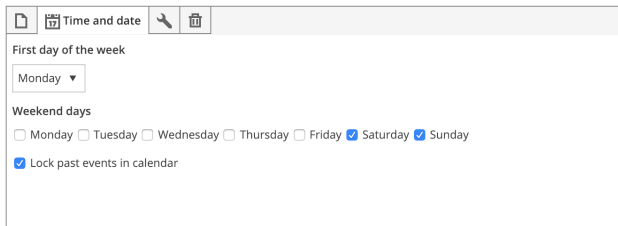

Time and date

First day of the week
Monday

Weekend days
 Monday Tuesday Wednesday Thursday Friday Saturday Sunday

Lock past events in calendar

4.2.4 Administrator settings

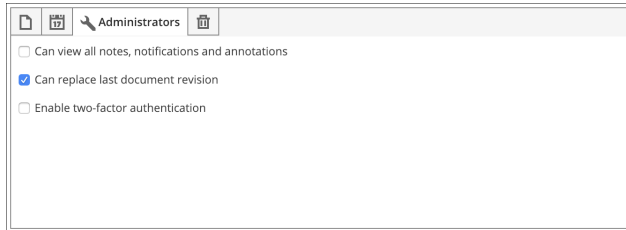

Administrators

Can view all notes, notifications and annotations

Can replace last document revision

Enable two-factor authentication

Can view all notes, notifications and annotations

Enable administrators to view all private notes, notifications and annotations. Users will be informed that the message can be read by administrators of the project when creating a new private message.

Can replace last document revision

Allow administrators to upload a revision to a document and check the option "Replace last revision" in the upload dialog. A feature that comes in handy when a wrong revision was uploaded and you need to replace it.

Enable two-factor authentication

Enable double authentication for this project. This means that users need to log in first to the system with their username and password but if they want to enter this project, a token will be asked for enhanced security.

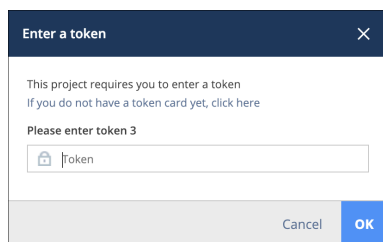

Enter a token

This project requires you to enter a token
If you do not have a token card yet, [click here](#)

Please enter token 3

Cancel OK

The user can request the token card in the dialog that asks for the token. An email will be send with a unique link to download the token card.

Example of a token card:

Bricsys® 24/7		
1. 1X6T1LGA	9. CE7BJR0Q	17. ZMD4QLPX
2. K6KXXA69	10. P3VTWMJB	18. YRYNMEKE
3. 8ZP0VP5Z	11. 6MGLHTNY	19. VASX70QA
4. 6WRFOXG7	12. 3PHBN9X5	20. 5FZSSW5P
5. OJC3LM9A	13. DRAYFNFF	21. 5QWHE9F9
6. R8DZCSYJ	14. EKABM2JE	22. ZJTXX8SV
7. 48M4I24T	15. GAVADRLH	23. 0IZAT8WC
8. FJB3K890	16. 7QSR00WD	24. NKZ2NSY5

Important: A token card is user specific and cannot be used by other members of the project!

4.2.5 Recycle bin settings

🗑️ Recycle bin

Lock recycle bin
 This option will make it impossible to remove items from the recycle bin. Once locked it can not be unlocked.

Lock the recycle bin if you don't want anything to be removed from the recycle bin. Note that once this is locked, it can only be unlocked by filing a Support Request to the Bricsys 24/7 team.

4.3 Structure

In the project structure, administrators can view, set up or edit the project structure. It is the core of every project and consists of folders and subfolders.

Folder	Description	Author	👤	🔗	🔧	🗑️	🔍
Documents		Jürgen Schepers	👤	🔗	🔧	🗑️	🔍
Building Application		Jürgen Schepers	👤	🔗	🔧	🗑️	🔍
Execution Phase		Jürgen Schepers	👤	🔗	🔧	🗑️	🔍
Final Design	All documents that were approved	Jürgen Schepers	👤	🔗	🔧	🗑️	🔍
Reports		Jürgen Schepers	👤	🔗	🔧	🗑️	🔍
Pictures		Jürgen Schepers	👤	🔗	🔧	🗑️	🔍
Document Management		Jürgen Schepers	👤	🔗	🔧	🗑️	🔍
UCO Tower	UCO tower in Ghent, Belgium	Jürgen Schepers	👤	🔗	🔧	🗑️	🔍
Workflows		Jürgen Schepers	👤	🔗	🔧	🗑️	🔍
Forms	Forms to be used as metadata	Jürgen Schepers	👤	🔗	🔧	🗑️	🔍
Visitors		Jürgen Schepers	👤	🔗	🔧	🗑️	🔍
Grouped docs		Jürgen Schepers	👤	🔗	🔧	🗑️	🔍
Internal Addressbook		Jürgen Schepers	👤	🔗	🔧	🗑️	🔍
External Addressbook		Jürgen Schepers	👤	🔗	🔧	🗑️	🔍
Messages		Jürgen Schepers	👤	🔗	🔧	🗑️	🔍
Discussion Forum		Jürgen Schepers	👤	🔗	🔧	🗑️	🔍
Calendar		Jürgen Schepers	👤	🔗	🔧	🗑️	🔍

Furthermore, administrators can subscribe users to certain folders and attach a workflow or a form to a folder in this part of the Administration app.

4.3.1 Project tree

The project administrators define a hierarchical list of all the folders in the project.

User can see this structure (or parts of the structure, according to the access rights) in the Structure App.

4.3.2 Structure inspector



The structure inspector is the last column on the right. It enables you to quickly have an overview of who can view the folder, attached workflows and forms...

Roles

The number of roles that have access to the folder. When hovering over the icon, an overview with all the roles that have access will be shown.

Folder subscriptions

Indicates if the users with access are subscribed to this folder by the administrator.

Workflows

The number of workflows that are attached to the folder. When hovering over the icon, the attached workflows with their options are shown. You can delete the workflow or edit the settings.

Forms

Indicates the number of forms that are attached to the folder in order to use metadata for documents. When hovering over the icon, the attached forms with their options are shown. You can delete the form or edit the settings.

Synchronized

Synchronize your documents with third party applications.

4.3.3 Add Folder

Add folder

To add a folder to your structure, select the folder type, choose a name and set the default access rights. It's recommended to group folders of the same type.

Folder type: Documents
Name: Approved documents

Add before: (Add as last)

Description: Gather all the approved documents here after approval using the workflow.

Choose the default access rights for all roles

Actions: [Icons for visibility, print, download, add, refresh, delete, edit, share, etc.]

Rights: [Table with columns for roles and checkboxes for rights]

• Disabled Enabled for own items Enabled for all items

Cancel Add

To set up or to expand the structure of your project, you have to add folders and subfolders.

There are two ways to add a new folder:

- Add folder from the action menu on top. This will create a new root folder.
- Add new folder, under one of the existing folders. This will create a new folder under that folder.



After you selected **add folder**, follow the next steps:

1 Folder type

Each type of folder represents an application in the application bar on the left.

 Document folder

 Address book folder

 Workflow folder

 Messages folder

Optionally enable fetch mail functionality to import all the emails of an email address in the Bricsys 24/7 App. This is often used for an email address that's only used for the project, to rapidly gather external email messages.

 Calendar folder

 Forms folder

 Link folder

 Forum folder

Separator: Use a separator to create a space in the structure.

 Binder

Optionally select only document with a status. The binder will show only documents with the chosen status. Documents with another status can be added to the binder but they won't be shown.

After the status is changed to the selected binder-status, the document will be shown in the binder. It's used to give a group of users only access to documents with a certain status.

For example: A group of users only can only see the approved versions of a document.

Important: The binder folder is set to show documents with statuses **Approved** and **Approved with comments** only. If you want documents with other statuses to be shown, you can change it manually in the settings of the binder folder.

 **BIM**

2 Fill in name

Fill in the name of the folder you add.

3 Add before

Select an existing folder and the new folder will be added before the selected folder.

After you created the folder, you can easily drag and drop the folder to another place in the structure settings.

4 Description (Optional)

Add a description to your folder.

5 Default access rights (Optional)

Choose the default access rights at once (for all roles) or if you are adding a subfolder you can choose to copy the access rights from the parent folder.

Note: The apps in the App bar on the left will only appear when you created a folder that's linked to an application and you have access to that folder.

6 Picture (Optional)

Add a picture to your folder. At the moment only BIM folders show the picture in the app.

4.3.4 Folder subscription overview

Manage the folder subscriptions of the project.

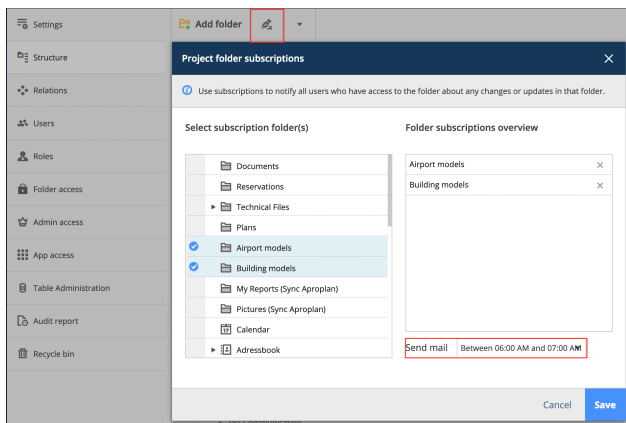

4.3.5 Add workflow

Attaching a workflow to a folder to start a workflow for each new document and revision (if specified). You can only execute this action on document and messages folders. Please keep in mind that only released workflows are visible.

- 1 **Hover over the folder**
- 2 **Select the action to add workflow**
- 3 **Select the workflow you want to attach**
- 4 **Choose a coordinator for the workflow**
- 5 **Optionally**

Start a new workflow for every revision

Start workflow when a revision is uploaded. Every time a new revision is added to a document, a new workflow will start. Thus there will be a workflow for every revision.

Cancel previous workflow

Cancel the previous workflow when adding a new revision. If you selected the “start workflow when a revision is uploaded”-option you can cancel the workflow of the previous revision when a new revision is uploaded.

Apply the workflow to all subfolders.

6 The workflow will start automatically

The workflow will start automatically when someone uploads a document in the selected folder.

4.3.6 Add form

Attach a Form to a folder and use the form as metadata. You can only execute this action on document folders. (See Form App)

- 1 **Hover over the folder**
- 2 **Select the action add form**
- 3 **Select the form you want to attach**

Previously you could only attach forms that contained a document field. In this document field you could then choose whether the metadata was stored at the document level or at the revision level. This is no longer the case.

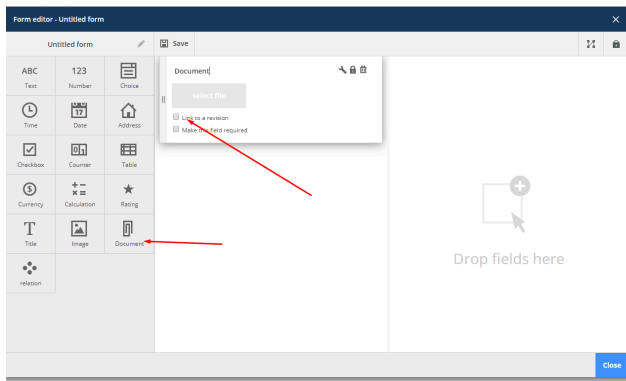

It is now possible to attach all forms to a folder and in case there is a document/revision field in the form, the level at which the metadata is stored will be chosen, based on the document field.

If there are no more (or more) document fields in the form, you can choose with this new option at which level the metadata will be stored. There should not be any changes to existing links between forms and folders and the reading of the data will remain as it used to be.

However, if you now move a document to a folder with no form attached, you will still be able to see the metadata.

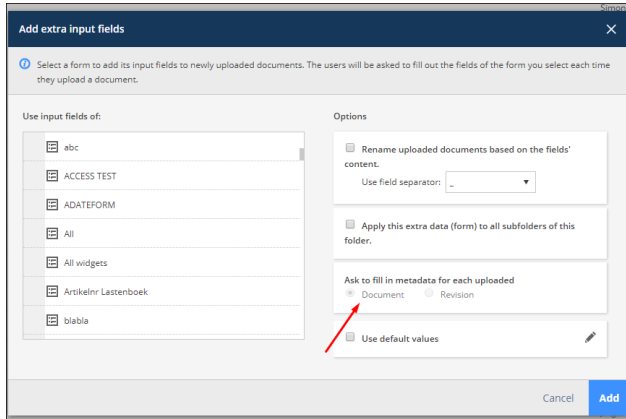

It is important to know that only forms with a document field are selectable as metadata.

1 Optionally

Rename uploaded documents based on the fields' content

Rename uploaded documents based on the content of the fields and automatically generate a name.

Select the separator that will connect the content of the fields: _ / , / - / . / Space.

For example

When a user uploads a document and fills in a form:

- Document type (invoice, plan, other): plan
- Discipline (Decoration, Electrical, furniture, HVAC, plumbing, Safety, Structural): Electrical
- Floor (-1,...,4): 3

The document will be renamed to **Plan_Electrical_3** after upload.

- Use default values

Fill in predefined values.

- Apply this meta data (form) to all subfolders of this folder.

2 Save

3 The form will be used as metadata

Each time a document is added to the folder, you can (or have to) fill in the form fields.

Remember: If you want the uploader to fill in required fields, select the **Make this field required** option in the settings of the form field.

4.4 Users

Invite users to the project and make them a member of certain roles.

Add user				
User	Email address	Account sent	Last logon	
<input type="checkbox"/> Bricsys Developer	dev@bricsys.com	02/19/2019		1
<input type="checkbox"/>  Bricsys Support	info@bricsys247.com	01/21/2019	Today 05:33 PM	1



4.4.1 Add user

You can add users who already are on Bricsys 24/7 or create a new user on Bricsys 24/7.

Note: Always search for users based on their email address.

4.4.2 Send account information

Send account information to the user. Make sure to type a personal message to the account info you are sending.

The account info e-mail contains a unique link for the user to set or reset the password.

4.5 Roles

View, edit or add roles and their specifications.



4.5.1 Role inspector



 Number of people in the role

 Permission to see other users

 Permission to see revisions

 Permission to see their profile

 Mail list of the people who are assigned to this role

4.5.2 Add role

You can create a new role or copy an existing role from another project.

Create a new role

1 Name the role

2 Optionally

- Use as a mail list

If you want to send an instant message to all the members of the role

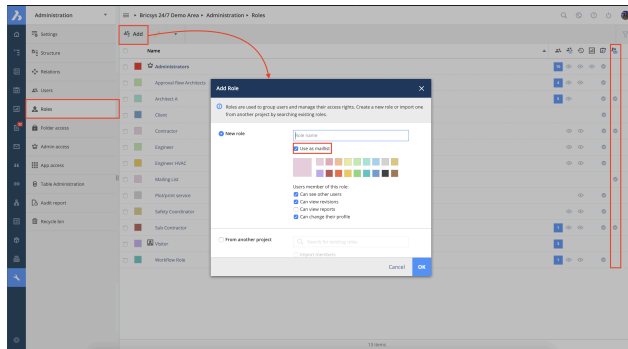

As project administrator you can setup roles so they can be used as maillists. Whenever you modify an existing role or add a new role, you can indicate whether this role should be used as a maillist by selecting the check box **use as maillist**. Once this option is checked every next notification or annotation can be sent automatically to all users who are members of this particular role. E.g. If for the role "Engineers" the admin enables the checkbox **use as maillist** all members of the role "Engineers" will be notified (instead of notifying each user of the role "Engineers" separately).

- Members of this role can see other members

If the users in this role cannot see other members they are not able to send notifications to other users.

- Members of this role can view revisions
- Members of this role can change their profile

The members can change everything int their profile: profile picture, email, password, folder subscriptions...

Import a role from another project

- 1 Searching existing roles from other projects (Please note that folder access rights will not be copied while importing any role. The folder structure is usually different in every project and folder access rights would not always be compatible if they were all copied.)
- 2 Optionally import members of the role (Please note that folder access rights will not be copied while importing any member. The folder structure is usually different in every project and folder access rights would not always be compatible if they were all copied.)

4.6 Folder Access

Give access rights to roles. You can select a folder and set the access rights per role.

By Folder	For:	Architect A																	
Documents																			
Reservations																			
Technical Files																			
New Technical Files																			
Approved Technical Files																			
Approved Technical Files - without notes																			



4.6.1 Folder access inspector

- Viewing rights
- Printing rights
- Downloading rights
- Adding object rights
- Adding revision rights
- Annotating rights
- Editing rights
- Deleting rights
- Attaching a workflow rights
- Adding a subfolder rights
- Sharing rights
- Attaching a form rights

4.6.2 Access types

- No access
- Access own: Rights to objects the user created or uploaded himself in the folder
- Access all: Rights to all objects in this folder

4.6.3 Selection bar

Easily switch between **By role** and **By folder** view.

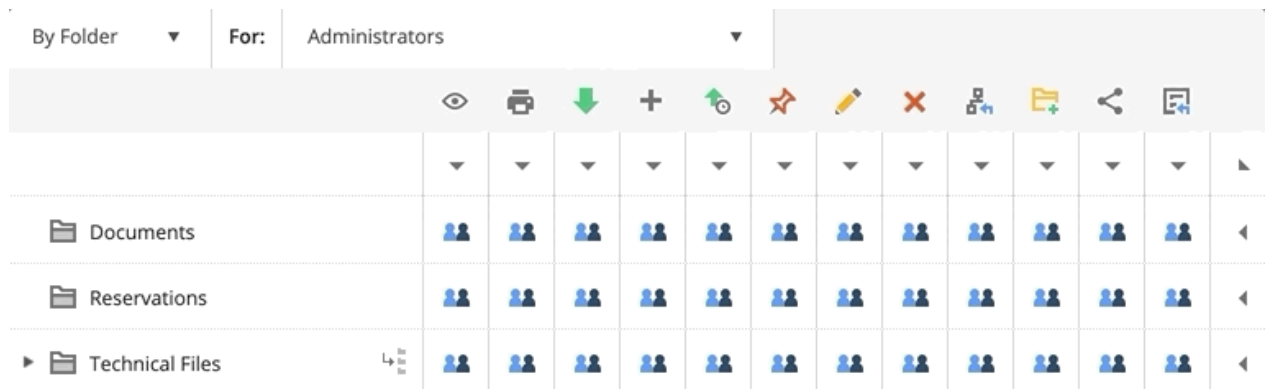

4.6.4 Toggle access

You can use the top and right handles to quickly toggle the access rights:

- no access

- access own
- access all

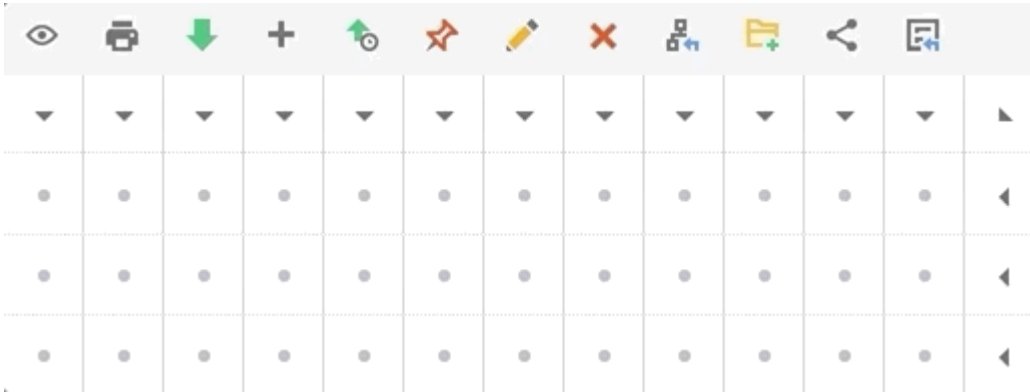

4.6.5 Create Snapshot

Take a back-up of your access rights at this moment in time.

4.6.6 Revert Snapshot

Revert to the access rights to a previously saved snapshot.

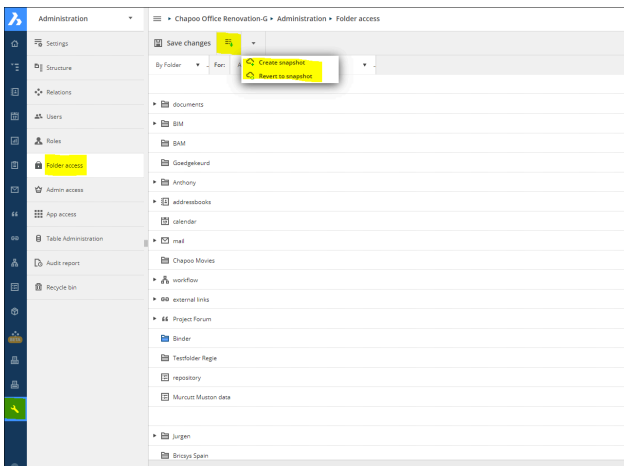

4.7 Admin Access

Define the administrator categories an administrator has access to.

Save changes		Administrators									
		🔍	📄	👤	🔒	📄	📄	📄	📄	📄	📄
Bricsys Developer		👤	👤	👤	👤	👤	👤	👤	👤	👤	👤
Bricsys Support	Project owner	👤	👤	👤	👤	👤	👤	👤	👤	👤	👤

4.7.1 Access

The access is split up like the categories in the administration app.



	Change the settings of the project
	Add, edit or delete the folders
	Add, edit or delete users and roles
	Set access on the folders
	Set access on forms
	Set access on third party applications
	Create reports of the project activity
	Restore or definitely items
	Set access for administrators

Note: Note that the you cannot have folder structure access without folder access.

Note: Note that the project owner always has all admin access.

4.8 Table Administration

Easily define the access on the data of the forms and the form fields.

4.8.1 Table list

The table list shows all the available tables within this project. In general each table represents a form but some form fields might also represent a table:

- Choice field
- Table field

4.8.2 Data access

- 1 Select a role in the selection-bar

For: Architect ▼

- 2 Set the access

Click on the junction between the form or the form field and the right, to change the access right of the role in the form or form field. There are 2 kinds of access you can give for every right:

- No access



Access all

3 Save changes

4.8.3 What does access on the data mean?

Data access on the form

Access	Access in a form	Access in metadata
	User can view all the rows of the form	User can view the metadata
	User can add a new row to the form	User can add metadata when uploading a document
	User can edit an existing row of the form	User can edit metadata of an existing document if the user can edit the document
	User can delete a row of the form	-

Data access on the form field

Access	Access in a form	Access in metadata
	User can view the form field's data	User can view the form field's metadata
	User can add data to this form field when creating a new row	User can add metadata to this form field when uploading a document
	User can edit existing data of this form field	User can edit metadata of this form field of an existing document if the user can edit the document

4.8.4 Data Access example

A form "Metadata" has been created with four fields:

- Discipline
- Building
- Document type
- Document



The role Architects has the following access.

For:	Architects					
▼ Metadata						
Discipline						
Building						
Document type						
Document						

This means that everyone in the role Architects:

- can view all the rows / can view the metadata
- can add a new row / can add metadata
- can edit an existing row / can edit existing metadata
 - but cannot edit the value of / cannot edit the metadata of
 - Discipline form field
 - Building form field
- cannot delete an existing row/-

4.8.5 Download list

Download a list of all records of the form.

4.8.6 Upload CSV

If you have existing data that you want to add to a form in Bricsys 24/7 you can export your data to a UTF-8 CSV file.

Make sure the data is formatted correctly in the CSV file in order for the system to process the data correctly.

Choice field	Make sure the value is exactly like it looks in Bricsys 24/7: "Name, description"
Date field	We support multiple variations for date field: <ul style="list-style-type: none"> • yyyy-MM-dd • yyyy/MM/dd • dd-MM-yyyy • dd/MM/yyyy
Document field	If you want to update or add metadata for existing files, use our REST API to fetch the document IDs.



ID	If you want to update an existing table, add an ID column with reference to the correct IDs. You can get the IDs by downloading the CSV file first using the Download list action.
----	------------------------------------------------------------------------------------------------------------------------------------------------------------------------------------

Make sure all required fields are added to the CSV file.

4.9 Audit Report

The audit report section is an incredibly powerful tool that let administrators search on everything that happened in the project.

Period	12/01/2018 - 01/08/2019	User	Bricsys Support	
Action	All	Filter on	Document	Search
Name	Action	User	Date	Folder
Tower Building B.dwg	Revise	Bricsys Support	12/27/2018 02:11 PM	Support
Tower Building B.dwg	Add	Bricsys Support	12/27/2018 02:11 PM	Support
Tower Building A.dwg	Share	Bricsys Support	12/27/2018 02:10 PM	Support
Tower Building A.dwg	Attach document	Bricsys Support	12/27/2018 02:08 PM	Support
Tower Building A.dwg	Add to binder	Bricsys Support	12/27/2018 02:07 PM	Support
Tower Building A.dwg	Open viewer	Bricsys Support	12/27/2018 02:03 PM	Support
Tower Building A.dwg	Add note	Bricsys Support	12/27/2018 02:03 PM	Support
Tower Building A.dwg	Edit	Bricsys Support	12/27/2018 01:57 PM	Support
Tower Building A.dwg	Add	Bricsys Support	12/27/2018 01:57 PM	Support

4.9.1 Selection bar

Specify the period and what you are looking for.

- Period
- Filter on
 - Objects
 - Actions
 - Users

4.9.2 Results

The result list exists of a list that contains the information about the actions:

- Name
- Action
- User
- Date of the action
- Folder where the object is stored

4.9.3 Search in action

Download list			
Period	11/01/2018 - 11/30/2018	User	All
Action	All	Filter on	All
			Search
Name	Action	User	Date

4.10 Recycle bin

All documents and items that are deleted in Bricsys 24/7 will be moved to the recycle bin first (soft delete) where only administrators have access. It is still possible to restore items from here (by selecting one or several files and clicking on 'Restore' icon) or delete them completely (by selecting a file and clicking on 'Delete' - in the drop down menu under the arrow icon). Once deleted in the recycle bin, items will be removed irreversibly (hard delete).

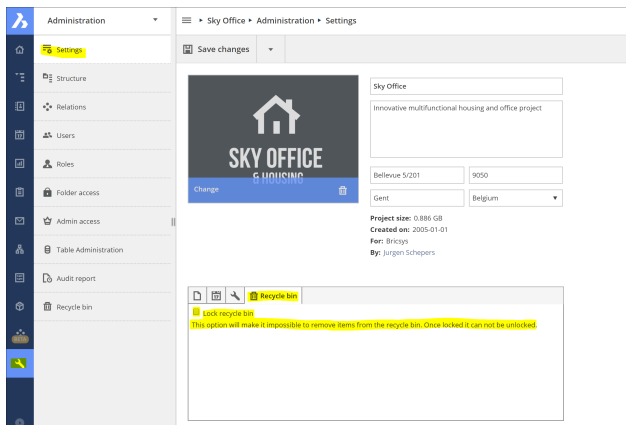

4.10.1 Empty Bin

Definitely delete all objects in the recycle bin. This cannot be undone!

4.10.2 Restore

Restore objects to their original folder within the project.

4.10.3 Delete

Definitely delete an object. This cannot be undone!

Important: In order to delete items from the Recycle bin the following option (**Lock recycle bin**) cannot be checked.

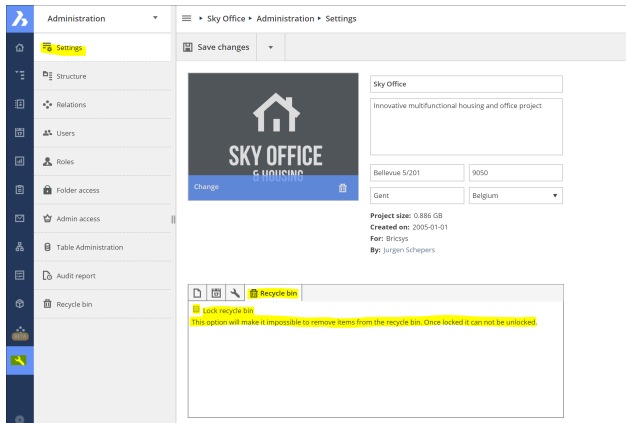

5. FAQ

5.1 I don't find the guest role anymore. How can I share information with guest users?

Sharing information

Since the **guest user** option is no longer available, you can use the share option.

You will not be able to share an entire project. However, you can share a document or a folder.

In the Structure app, click on the arrow of the dropdown menu and select **share document** to give access to that document for a guest user. From the same menu, you can choose the option **share folder** to share a specific folder.

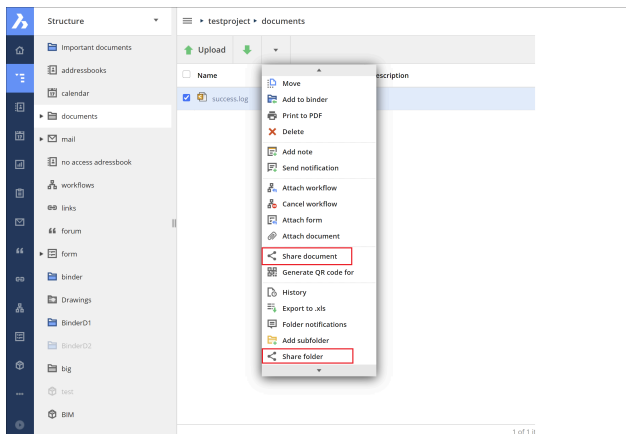

5.2 Is it possible to delete an annotation, a notification or a note ?

Annotations on Bricsys 24/7 are a great tool to comment on a specific area of the document. Notifications work in a similar way to emails and document notes look similar to sticky notes. All together they remain visible over all the revisions of a document and all of them are revision based which means that you cannot see the annotations, notifications or notes of previous revisions while viewing the latest version of the document. Also, it is **not possible to delete any of them** in order to keep the original track of a document that has been edited while the project runs.

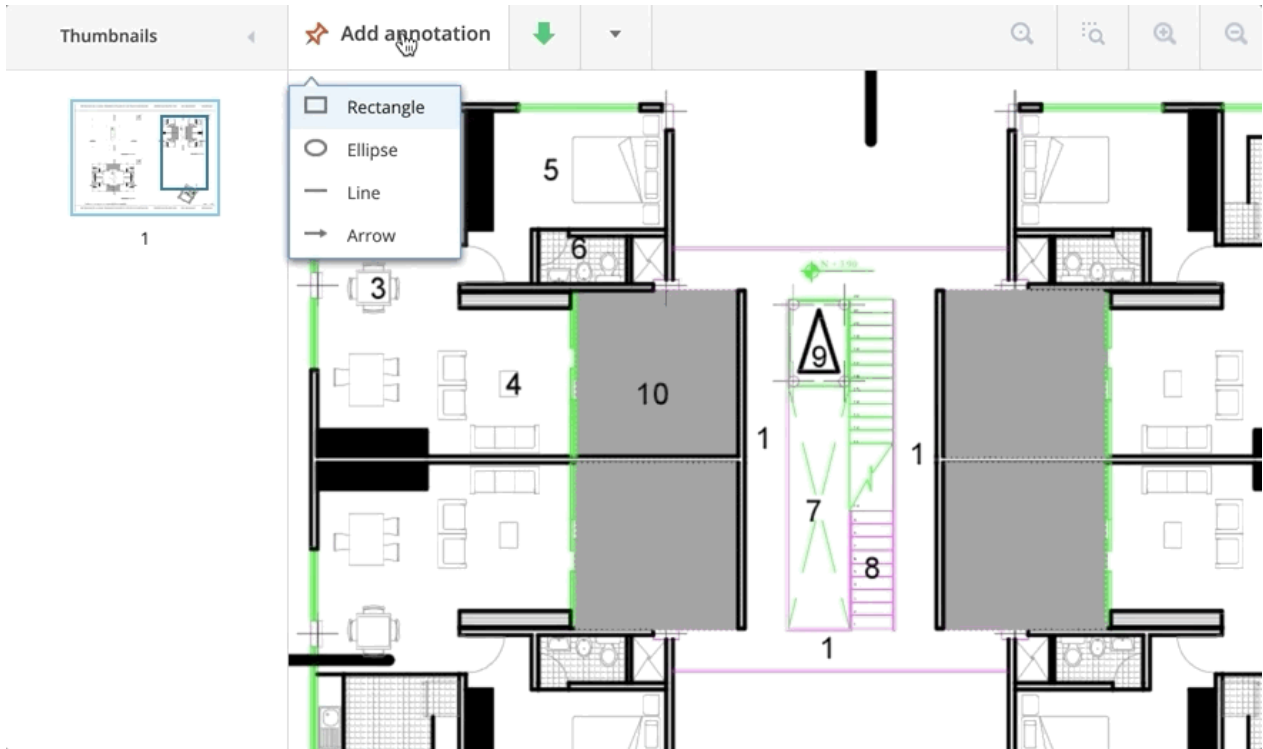

5.3 Problems logging in using the new Secure Login page

5.3.1 Why is there a new login system?

In December 2019 we transformed our logging system into a new unified login page for Bricsys 24/7 users. This new system will allow you and your users to access Bricsys 24/7, the Bricsys website, and other Bricsys products in a **more secure way**.

Below you can find the new Bricsys 24/7 unified login page.

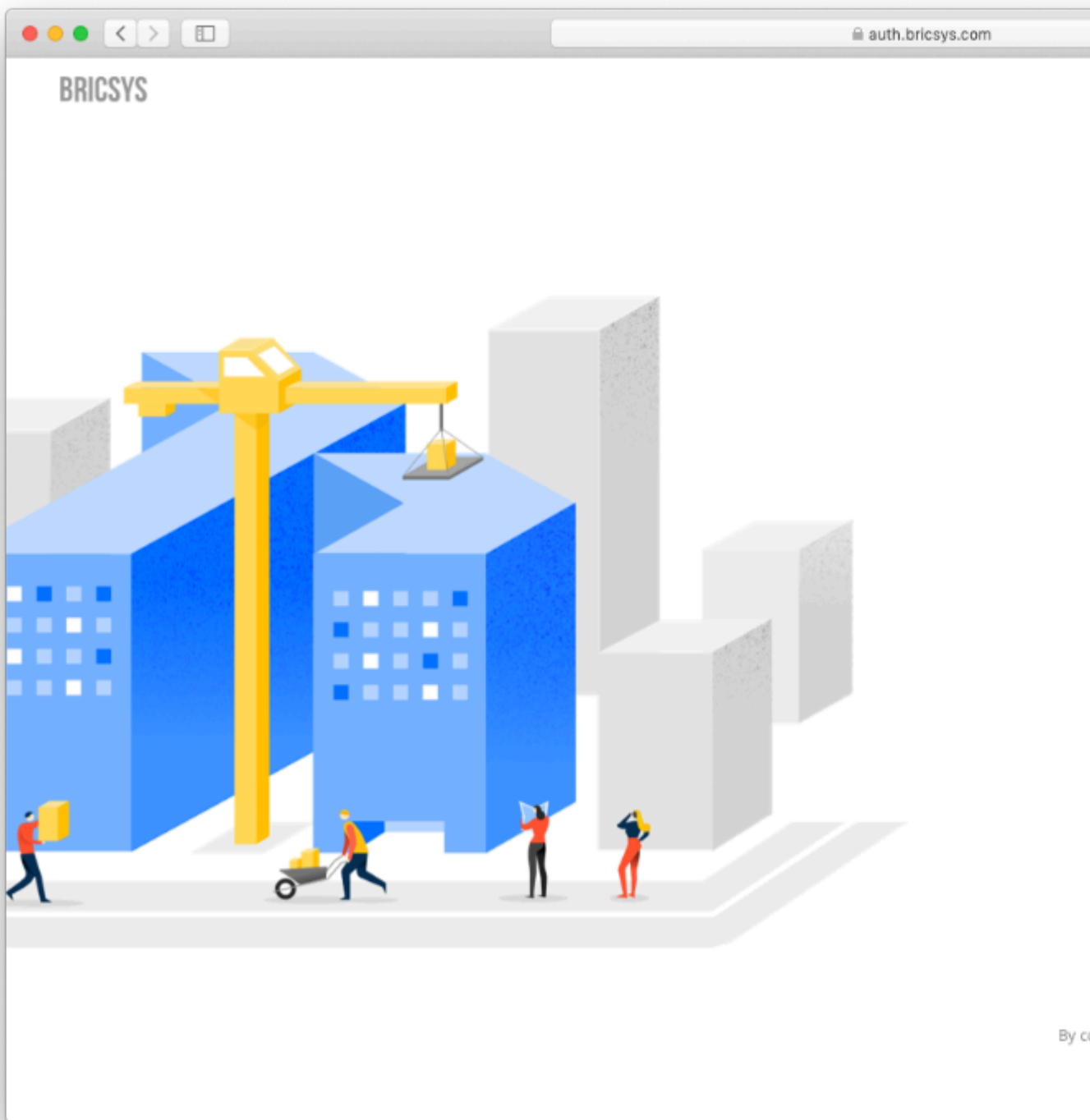

By c



5.3.2 What's changing?

Not that much. After the update, users will be able to log in with their current credentials. They will further be prompted to reset their password since our password requirements have been updated. If they can't remember their password, they should use the forgot password link.

Exception

Users with a username other than their email will need to sign up for a new Bricsys account. Afterwards they can log in on the Bricsys24/7 website with their new Bricsys account. They will be asked to verify their old Bricsys24/7 credentials in order to access their projects.

5.4 I don't see all applications in the app bar

The applications in Bricsys 24/7 are visible in the app bar on the left and their visibility depends on two factors:

- Folder type
- Access

5.4.1 Folder type

Each app represents a different folder type. The more folder types you have in a project the more possible apps that will be available.

Eg. In order to have the address book app you need to create a folder of type address book.

5.4.2 Access

The other factor is your access. If you have an address book folder in your project but you don't have access to it, the address book app will not be available.

The administrator of the project is the only one who can create folders and set access. If you are an administrator you can take a look at our [Add Folder on page 89](#) section which takes you through all the steps to create a new folder.

5.5 I can't send notifications about a document

When you want to send a notification and don't find the notification action for the document you're viewing, it's because the administrator in the project has disabled the option for you to see other users.

If you need to send a notification, you should contact the project administrator to change the [settings of the role](#) you're part of.

5.6 I don't see a specific user when sending a notification

When sending a notification or message you can only select the users that have access rights to the document.

If the user you want to send the notification to cannot see the item, the system won't show that user in the list of recipients.



5.7 I want to stop receiving task notifications in my email

It's possible to stop receiving task notifications by opening your [profile dialog](#) and checking the box "Stop task notifications".

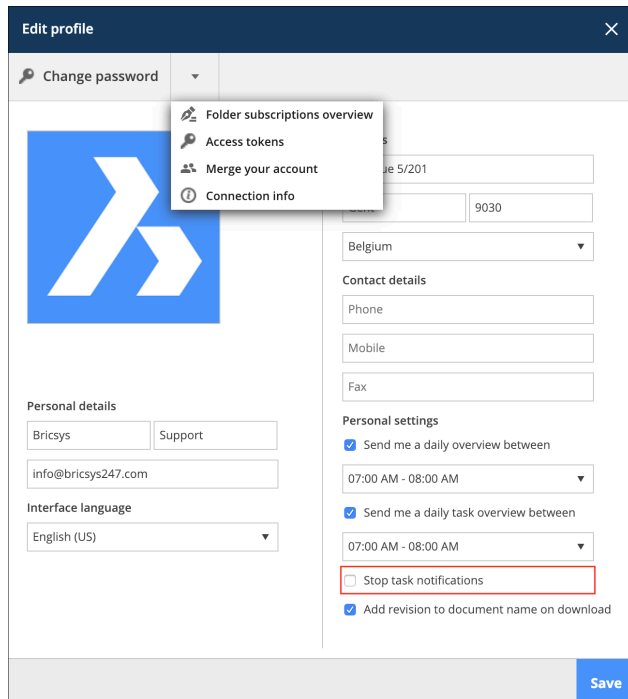

You will still be able to see your tasks in the [Dashboard](#) and the [Mytasks](#) app after logging into a project on Bricsys 24/7.

5.8 How do I reassign a workflow task to another user

With Bricsys 24/7 it's possible to reassign one specific workflow task or all the workflow tasks from one user to another user.

There are two users that can reassign a workflow task to another user:

- the workflow coordinator
- the project administrator

5.8.1 Workflow coordinator

The workflow coordinator can open a task and reassign that individual task to another user:

- 1 Click on the document.
- 2 Click on the **Workflow** tab.
- 3 Select an active workflow on the left side of the window and click on the 'eye' icon.

4

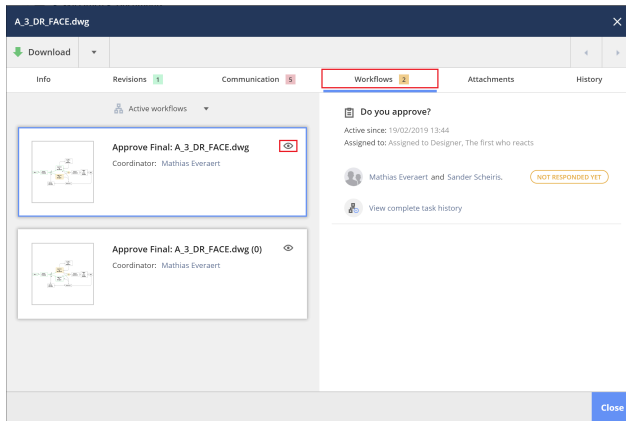

5 Click on one task underneath **Tasks** tab.

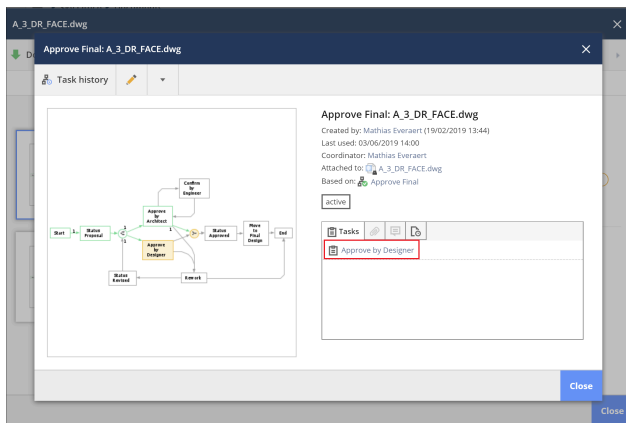

6 When you click on the arrow with drop down menu you find the action 'reassign actor' (note that there must be at least 1 other user in the role of the current actor).

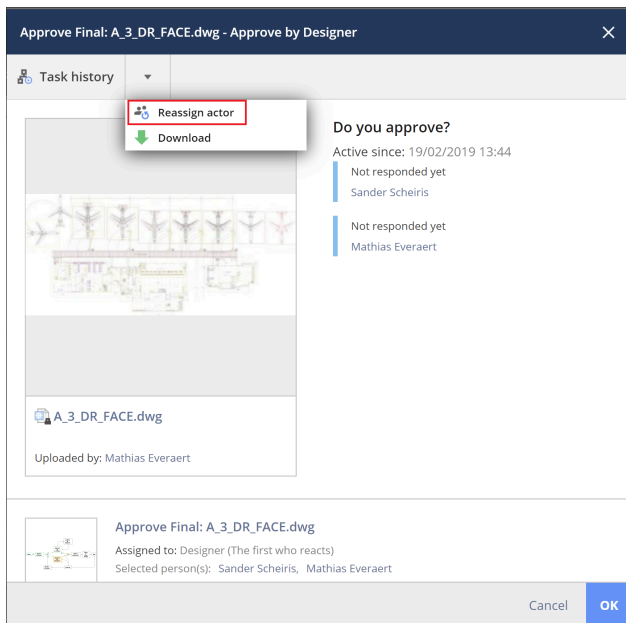

5.8.2 Project administrator

A project administrator can reassign all tasks of a specific user to another user in Users [on page 93](#) by using the **Reassign tasks** action.

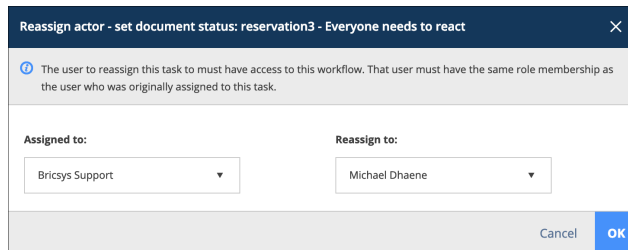

5.8.3 Requirements

In order to reassign tasks to another user, it's necessary that both users are in exactly the same roles.

5.9 Why is the workflow task assigned to another user

If you notice that a workflow task is assigned to another user rather than one of the users that are part of the role assigned to the task, it probably has to do with access rights.

5.9.1 Access rights

Once a workflow activity becomes active and the user doesn't have access to the item, the workflow coordinator will be assigned automatically to the activity.

To fix this, an administrator of the project will need to [give the role of the user access to the folder](#) in order to view the item.

5.9.2 Reassign actor

Once this is done, the coordinator of the workflow can open the task assigned to his or her name and use the **reassign** action in the menu.

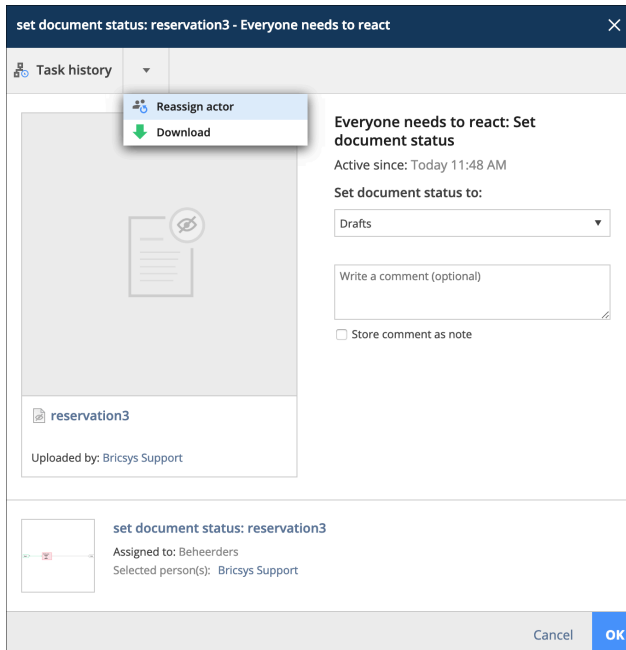

5.10 How do I delete a workflow

There are two factors that enable a user to delete a workflow:

- Delete access
- Workflow in use or not

5.10.1 Delete access

First of all you will need delete access for the folder where the workflow is located.

5.10.2 Workflow in use or not

Workflows can only be deleted if they have never been used before. This means that when a workflow has been used or is being used at the moment, the workflow cannot be removed.

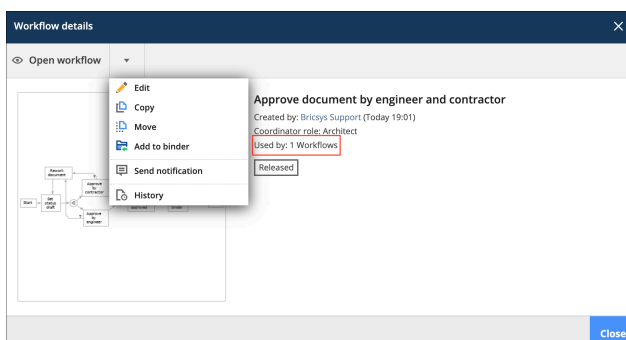

This is measure within Bricsys 24/7 to enforce project continuity, otherwise important data about a document eg. might get lost.

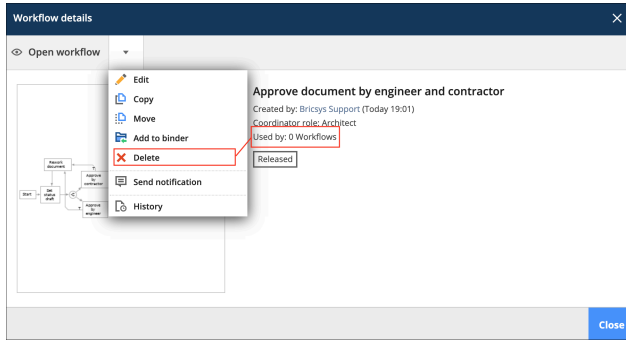

The only way to delete a workflow is, first - by removing documents where the workflow is attached to. Once the workflow has been removed, you'll see in the workflow details that it is not used anymore.